



# AUTONOMO



*SOLAR-POWERED MOTOR PACKAGES*

KIT **XQBPZ616** (6 Nm)

KIT **XQBPZ1012** (10 Nm)

KIT **XSBPZ2012** (20 Nm)

KIT **XQBPZ2016** (20 Nm)

KIT **XQBPZ309** (30 Nm)

---

KIT **XQBPLZ1012** SOLAR STATION (10 Nm)

KIT **XSBPLZ2012** SOLAR STATION (20 Nm)

KIT **XQBPLZ2016** SOLAR STATION (20 Nm)

KIT **XQBPLZ309** SOLAR STATION (30 Nm)

KIT **XQBPLZ5012** SOLAR STATION (50 Nm)



---

**Made in Italy**

---



**SAFETY**

**GENERAL**

**BATTERY SAFETY**

**MAINTENANCE**

**INSTALLATION**

**COMMISSIONING**

**REPLACING A SOLAR PANEL**

**PROGRAMMING TRANSMITTER**

**ADDING TRANSMITTER**

**CHECKING/CHANGING DIRECTION**

**ERASING TRANSMITTER**

**RESET MOTOR MEMORY**

**LIMIT SWITCH SETUP**

**INTERMEDIATE POSITION**

**DE/ACTIVATING OBSTACLE SENSITIVITY**

# SAFETY



**CAREFULLY FOLLOW THESE INSTRUCTIONS. IT IS VERY IMPORTANT FOR THE SAFETY OF PERSONS. SAVE THESE INSTRUCTIONS. IMPORTANT:**

- Check the shutter/awning in motion and keep persons far from it while in action.
- Frequently check if any loss of balance, signs of wear or damaged wires are shown.
- Do not use if any repairing or maintenance is needed.
- In case of installation in awnings keep a distance of at least 0,4 m from it (completely open) and whatever fixed item in the nearby.
- The device is not intended to be used by people (including children) whose physical, sensory or mental capabilities are reduced, or lacking experience or knowledge, unless they have been granted through the intermediary of a person responsible for their safety, supervision or instruction concerning the use of the device.
- Children should be supervised to ensure they do not play with the device and / or with fix control devices.
- The control devices installed in a fixed manner must be positioned in view.

**ATTENTION: Damaged electric products and batteries should not be disposed of with normal household waste. Make sure to drop them in special provided containers or at an authorized organization that will ensure they are recycled.**

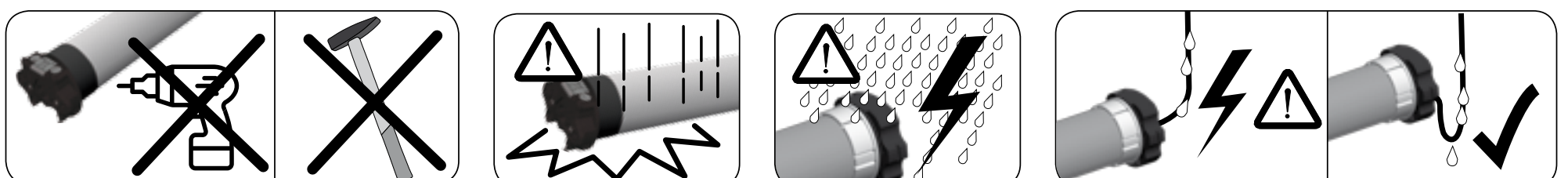

# GENERAL



## 1.1 FIELD OF APPLICATION

The XQ solar motor is designed for roller shutters and textile sun protection. The motor has to be installed in accordance with the standards of the country: the installation of the motor in the roller shutter must comply the EN 13659.

## 1.2 POWER SUPPLY

The XQ AUTONOMO is a motor working with solar energy. The power generated by the solar panel is stored into the battery pack.

## 1.3 XQ AUTONOMO packages include:

### SOLAR MOTOR KIT

- XQBPZ... DC12V tubular motor with 25 cm cable and connector
- Solar panel SPM18/30 with cable and connector
- Battery pack BNH22/23/24 with cable and connector
- Pack BB22 = battery brackets, AXRRF4 crown adapter, AXT45 round to star adapter

### SOLAR MOTOR KIT WITH SOLAR STATION

- XQBPLZxxx DC12V tubular motor with cable and waterproof connector
- Solar panel + battery in alu profile SPB18/22 with cable and waterproof connector
- AXT45 round to star adapter (in the XQBPLZ1012 motor only)
- AXRRF4 crown adapter (in the XQBPLZ1012 motor only)

**ATTENTION: battery BNH22/23/24 and solar panel SPM18/30 or the energy unit SPB18/22 must be installed on the same side where the motor is installed.**

## 1.4 Optional:

- NI-MH battery charger
- FLAXTWCC Twin connection Y cable
- kit with magnetic connectors FLAXMC-NI
- TDF3M double face tape
- BCC15NH charge cable to waterproof connector
- FLAX31W021 extension cord with waterproof connectors

# BATTERY SAFETY



- Do not dismantle, open or shred secondary cells or batteries.
- Do not expose cells or batteries to heat or fire. Avoid storage in direct sunlight.
- Do not short-circuit a cell or a battery.
- Do not subject cells or batteries to mechanical shock.
- In the event of a cell leaking, do not allow the liquid to come in contact with the skin or eyes. If contact has been made, wash the affected area with copious amounts of water and seek medical advice.
- Do not use any charger other than that specifically provided for use with the package.
- Observe the plus (+) and minus (-) marks on the cell, battery and equipment and ensure correct use.
- Do not use any cell or battery which is not designed for use with the equipment.
- Battery usage by children should be supervised.
- Always purchase the battery recommended by GAPOSA for the specific XQ AUTONOMO package.
- Keep cells and batteries clean and dry.
- Secondary cells and batteries need to be charged before use. Always use the correct charger and refer to the manufacturer's instructions or equipment manual for proper charging instructions.
- Do not leave a battery on prolonged charge when not in use.
- After extended periods of storage, it may be necessary to charge and discharge the cells or batteries several times to obtain maximum performance.
- Keep the original product literature for future reference.
- Use only the cell or battery in the application for which it was intended.
- Dispose of properly.
- Do not use a different battery charger than the one listed among the optionals.
- Do not exceed the maximum charging time of 3.5 hours.

# MAINTENANCE



The service life of the XQ AUTONOMO solar motor is between 3 and 5 years.

If the roller shutter/roller screen doesn't run properly and the motor does not return to normal operation after a sunny period, there has probably been a major discharge from the battery. The battery is required to be charged using a NI-MH battery charger, by a professional installer.

**Do not use a different battery charger than the ones supplied by GAPOSA.**

If this occurs again and after 3 years, the battery needs to be replaced by a professional installer.



## ASSEMBLY

- Only operate the motor in a horizontal position for its intended use.
  - If necessary, screw the star head adaptor on the motor head to conform the motor bracket and insert the crown and drive adaptors to match the inner profile of the rolling tube then insert the motor assembly into the tube.
  - Secure the idler on the other side of the tube to prevent axial movement using a screw or a rivet.
  - Do not drill holes on the rolling tube along the motor area
- 

## WIRING

- Keep 20 cm as minimum distance between 2 solar motors and 30 cm distance between motors and transmitters
- Cables which pass through a metal wall must be protected and insulated using a sheath or sleeve
- The motor cable cannot be removed. If damaged return the motor to the after sale service
- All the cables of the XQ AUTONOMO package are with connectors for a quick and easy plug of the entire system.
- The cable and connectors must be protected from the roller shutter movement.
- It is recommended to properly fix the cables inside the roller shutter box. Better if the connectors are placed behind the metal wall end.

### ATTENTION:

- **Any RF device at 434.15 MHz can interfere with a solar motor reducing the RF performances (Hi-Fi, radio, headphones)**
- **Always make a loop in the power supply cable to prevent water entering into the motor!**
- **Do not cut wires of the pre wired cables. The short circuit due to the cut will damage the components.**



 **Pay attention to the connections.**  
**Make sure that the color of the wires between the plugs and sockets is consistent.**

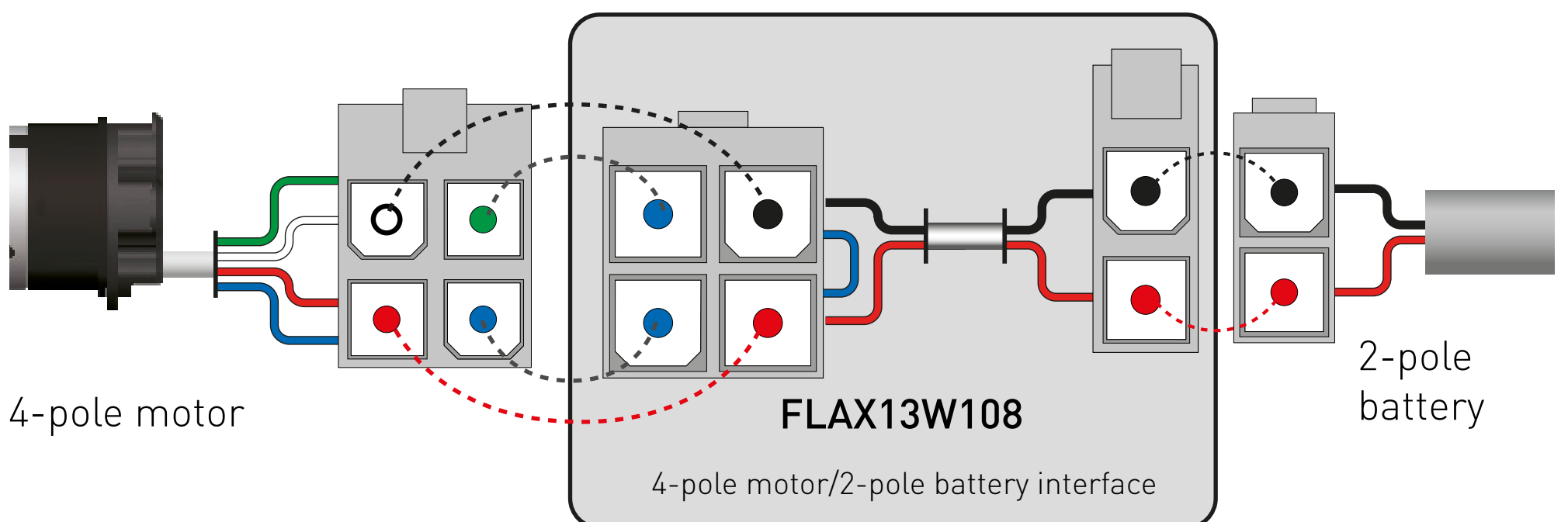
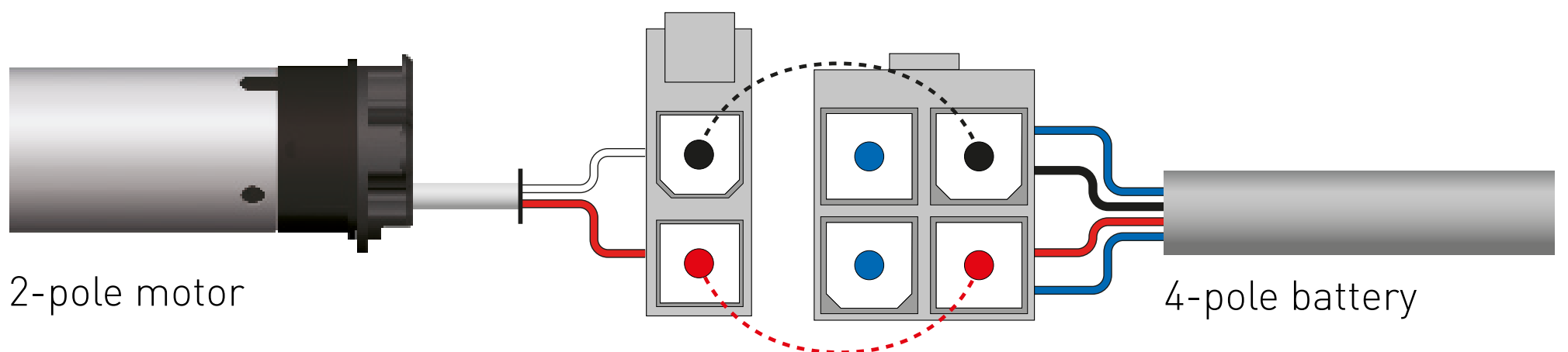
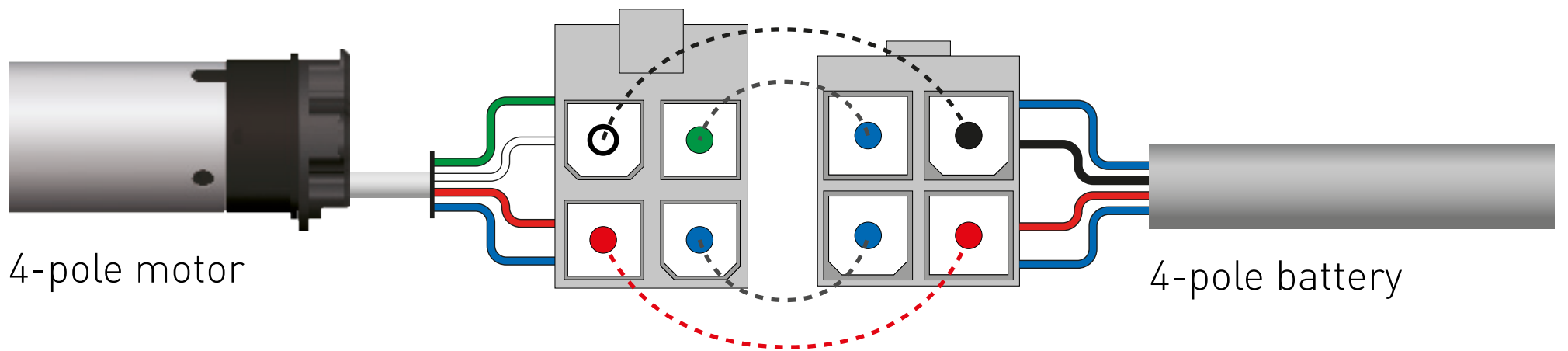
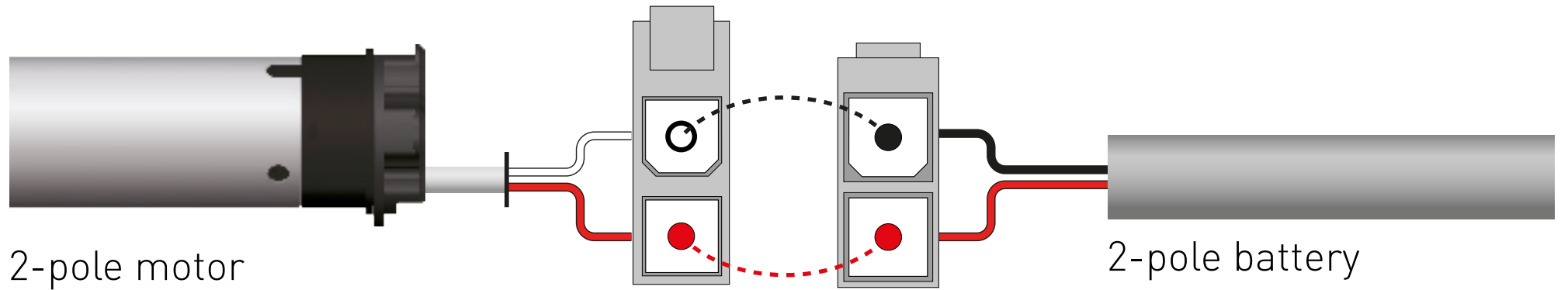



**⚠ Pay attention to the connections.**  
**Make sure that the color of the wires between the plugs and sockets is consistent.**

### KIT **XQ/XS BPZ**

#### 1. Standard Configuration

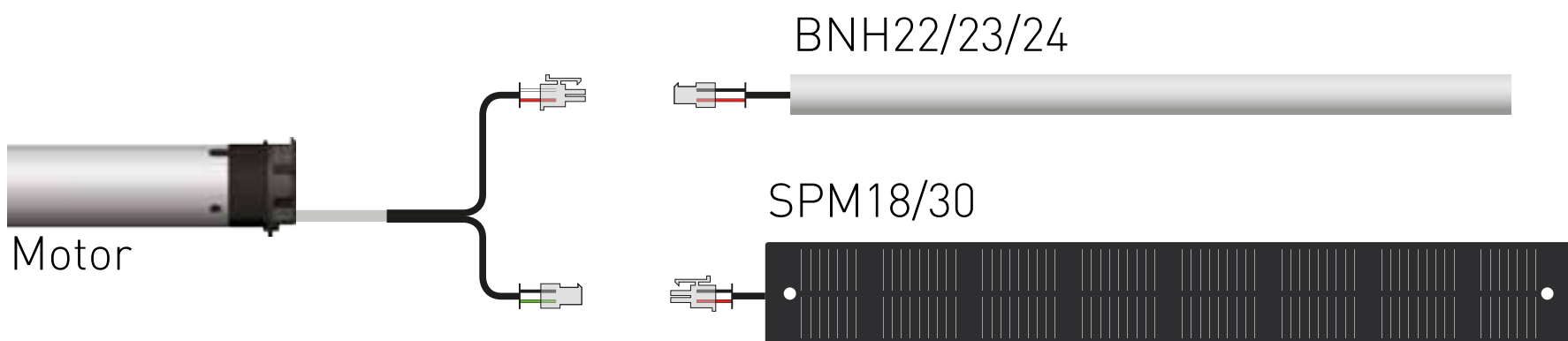

#### 2. Optional Configurations with FLAXTWCC connector

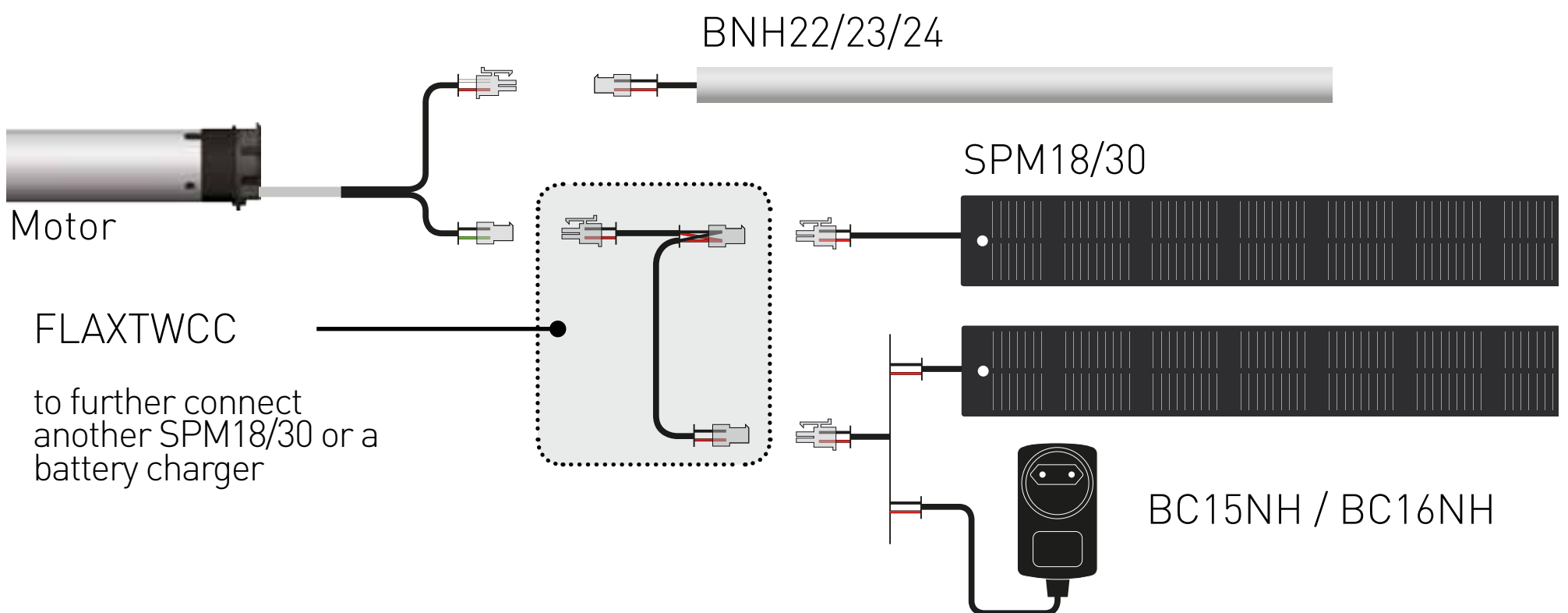

#### 3. Optional Configuration with charging kit with magnetic connectors FLAXMC-NI

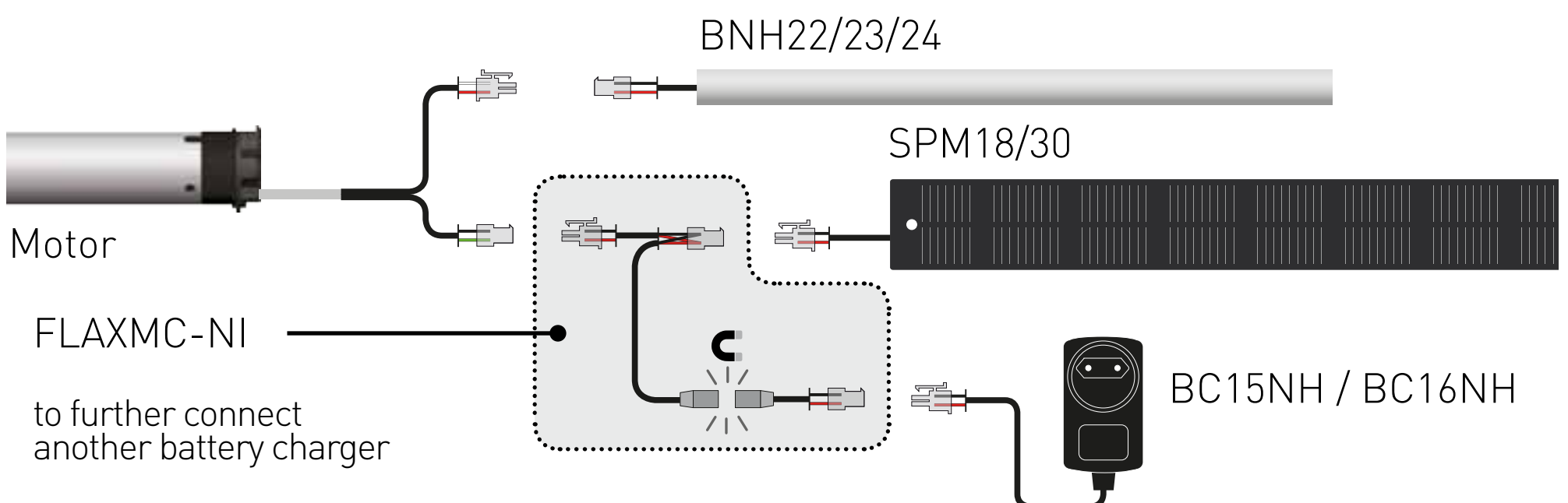



## KIT XQ/XS BPLZ

SOLAR STATION  
SPB18 (with < 50 Nm motors)  
SPB22 (with 50 Nm motors)

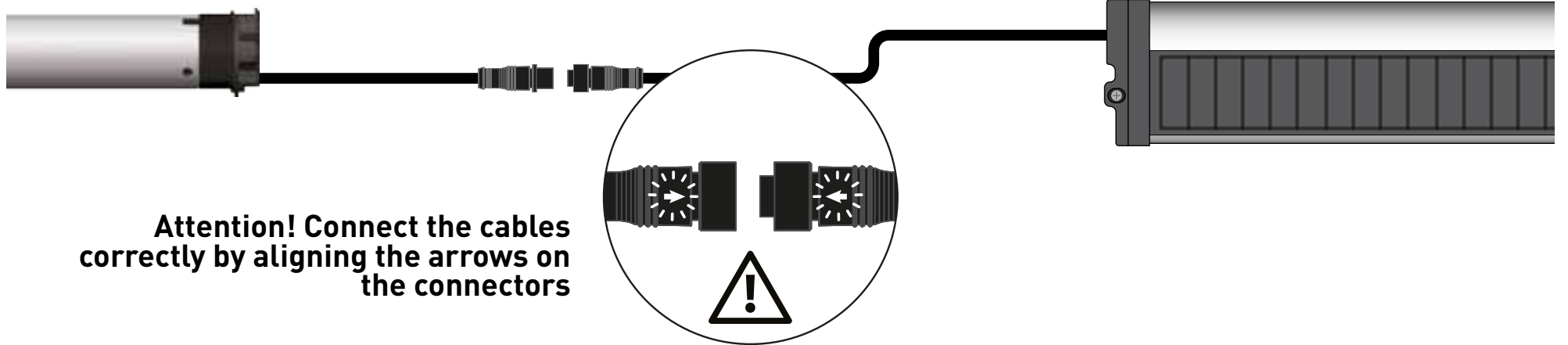

## CHARGER/BATTERY CONNECTION AND MATCHING DIAGRAMS

BC15NH /  
BC16NH

BNH22/23

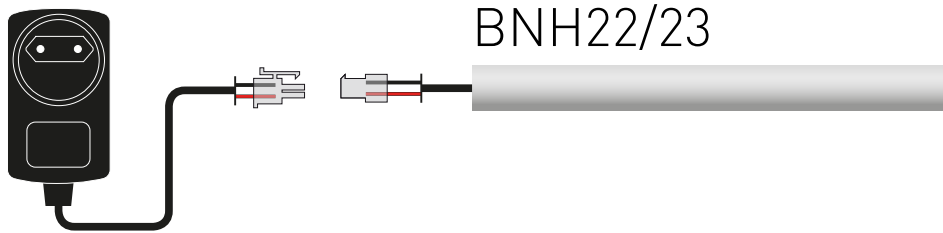

BC18NHD

BNH24

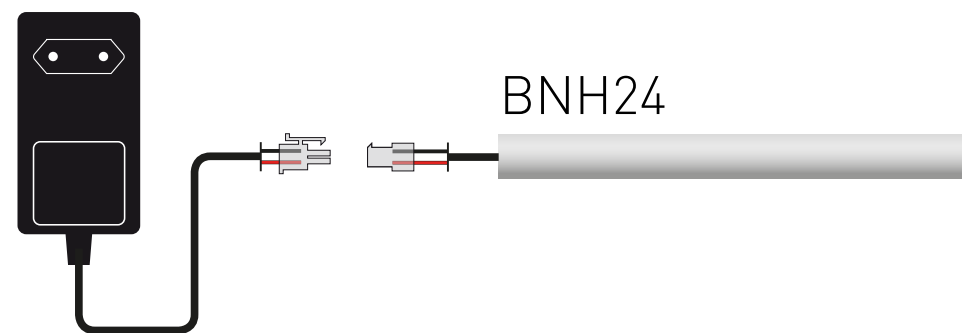

BC18NH

SOLAR STATION  
SPB22

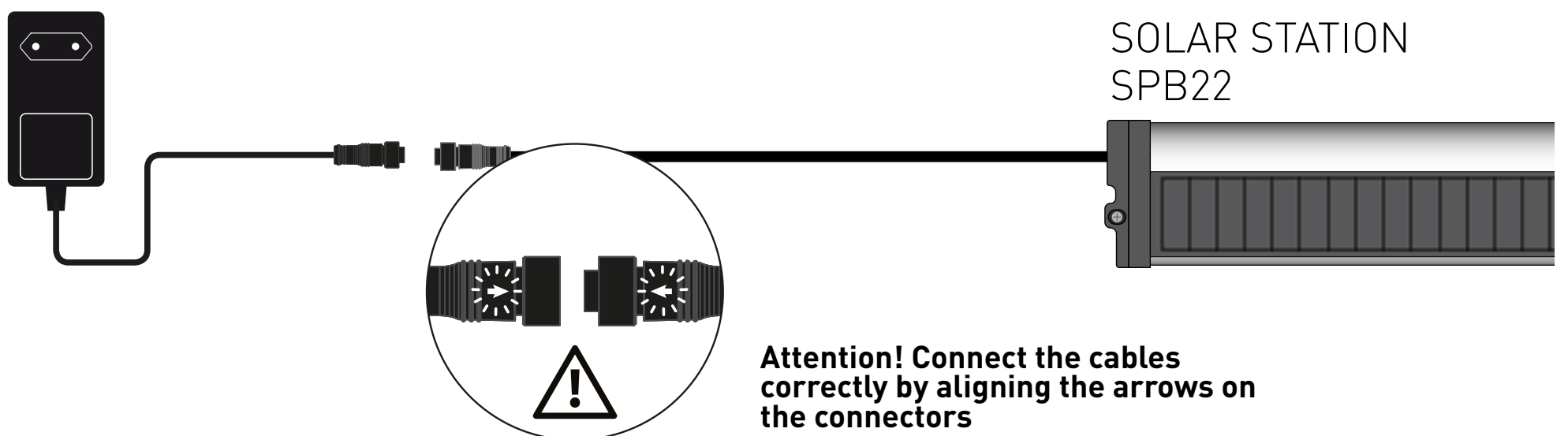

BC18NHD

SOLAR STATION  
SPB18

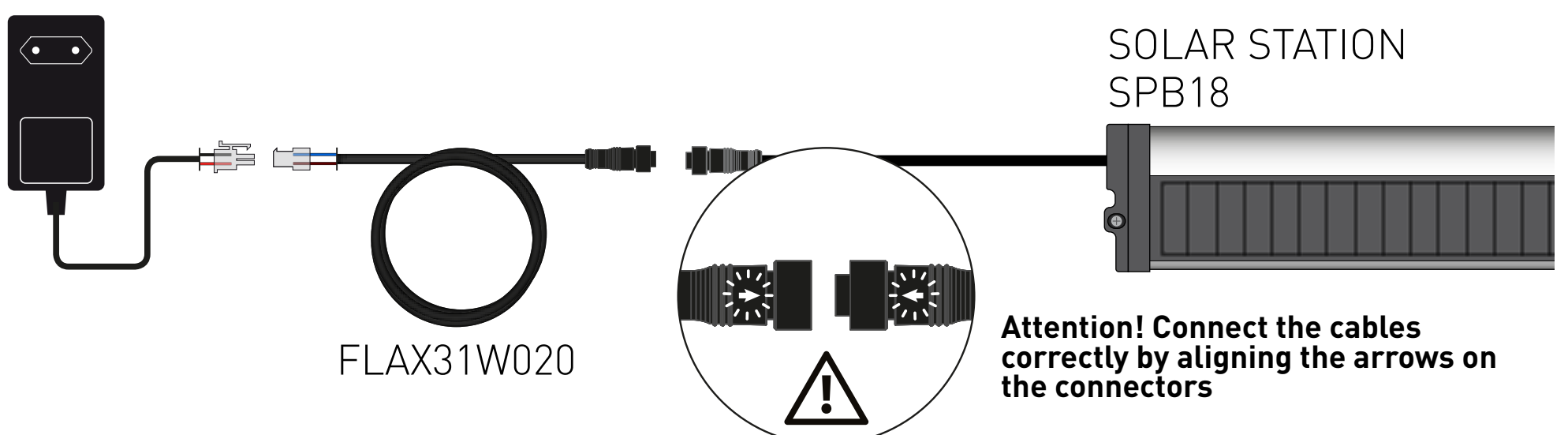



## SOLAR PANEL INSTALLATION

The solar panel (C) should be always placed on the shutter housing to be as much exposed as possible to the sun's rays.

Its position is critical and helps significantly the future autonomy of the solar motor system.

The solar panel(s), is sized to fit in all shutter boxes and to constantly charge battery for the daily movements.

In some areas where solar impact is very limited during some periods of the year there is an alternative solution to recharge the battery using the battery charger (as optional).

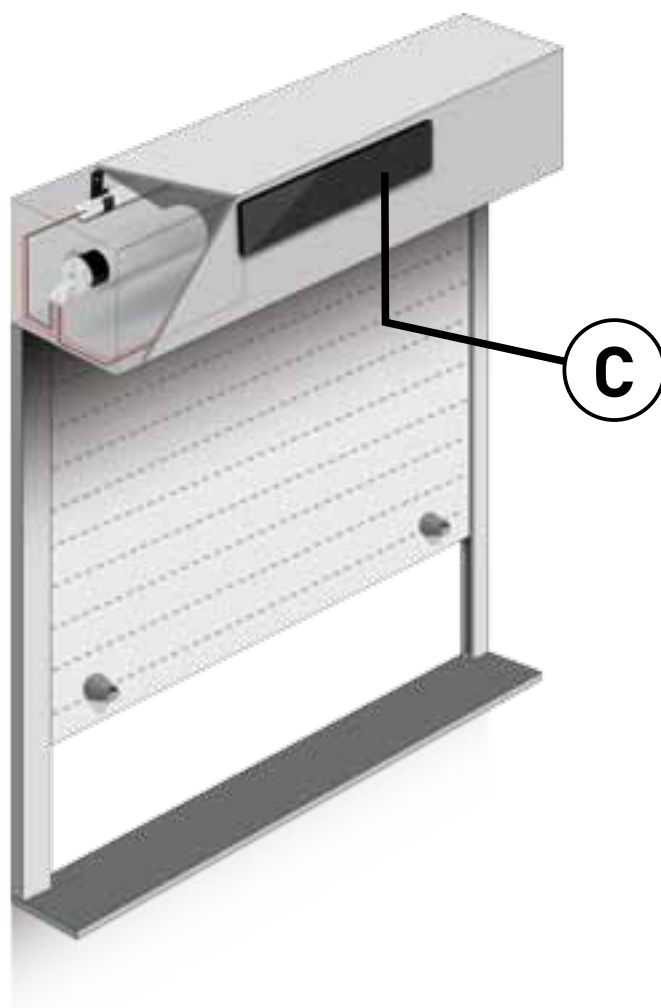

### ATTENTION:

- **Never install the solar panel in a horizontal position**
- **Never install the solar panel behind glass, or in the shade.**
- **Always leave the cells unobstructed, do not put anything in front of them.**
- **Never let snow accumulate on the solar panel, and that its complete surface is not covered by snow, leaves, etc.**
- **Keep the panel surface clean by cleaning it with clean water, using a soft cloth.**



## OPTIMAL PLACEMENT IN CASE OF OBSTACLES

Limited sight on the sky

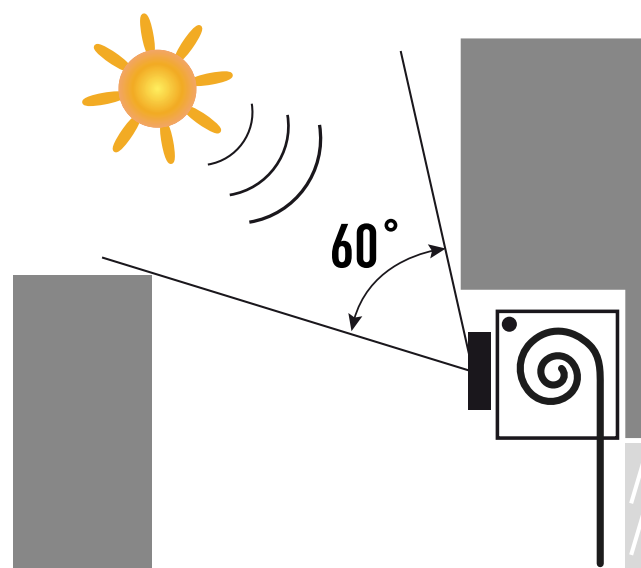

Roof overhang or similar coverings

$$L < 2 \times H$$

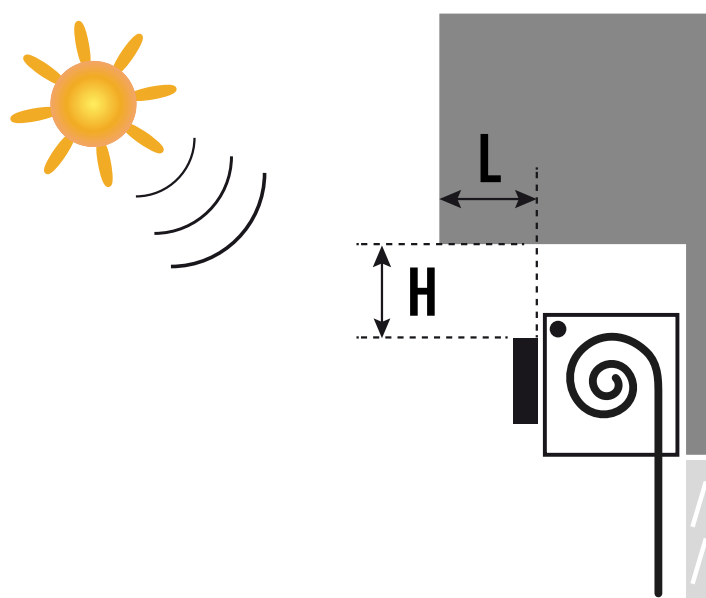

Moving the panel to the building front or another wall

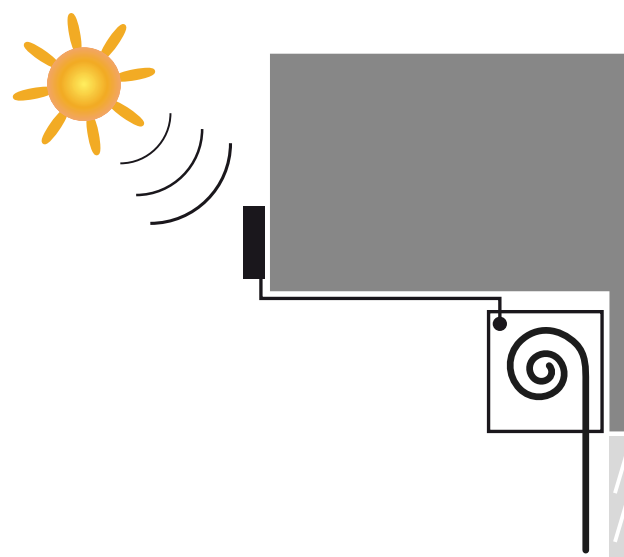

Obstacle in front of the solar panel

$$H < L / 2$$

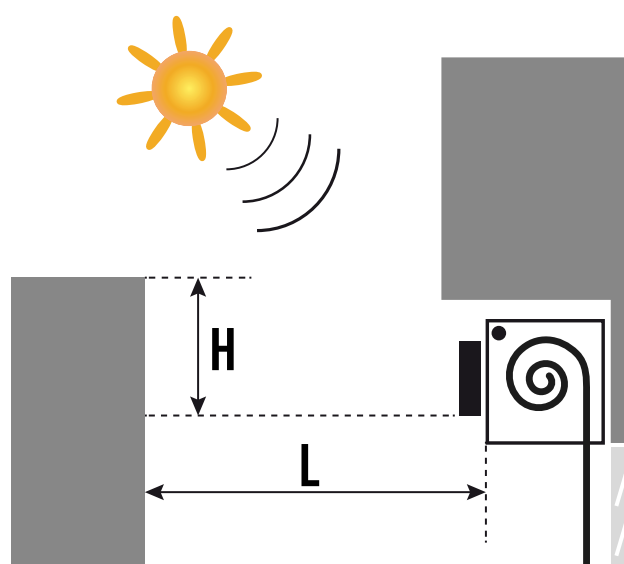



The panel can be fixed on the surface by using the 3M double tape or, for an absolute fixing solution, 2 pop rivets:

1. Drill 1 hole with diameter 0,5905 in (B) and 2 holes with diameter 0,1968 in (A) on the front of the casing, as per the diagram opposite.
2. Insert the solar panel wire inside the casing via the drilled hole (B). Protect the wire from the hole edges by positioning the protective foam.
3. Mount the solar panel in the two drilled holes (A), using aluminium pop rivets with diameter 0,1889 in and length 0,7362 in.

**IMPORTANT: don't use large washer which can go above the cells**

## SPM18

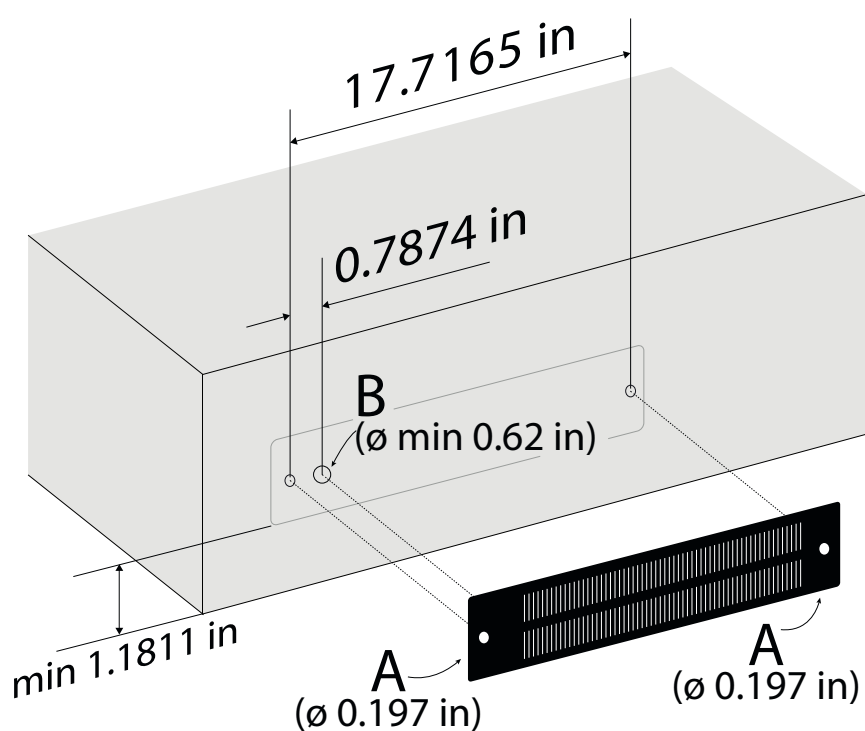

## SPM30

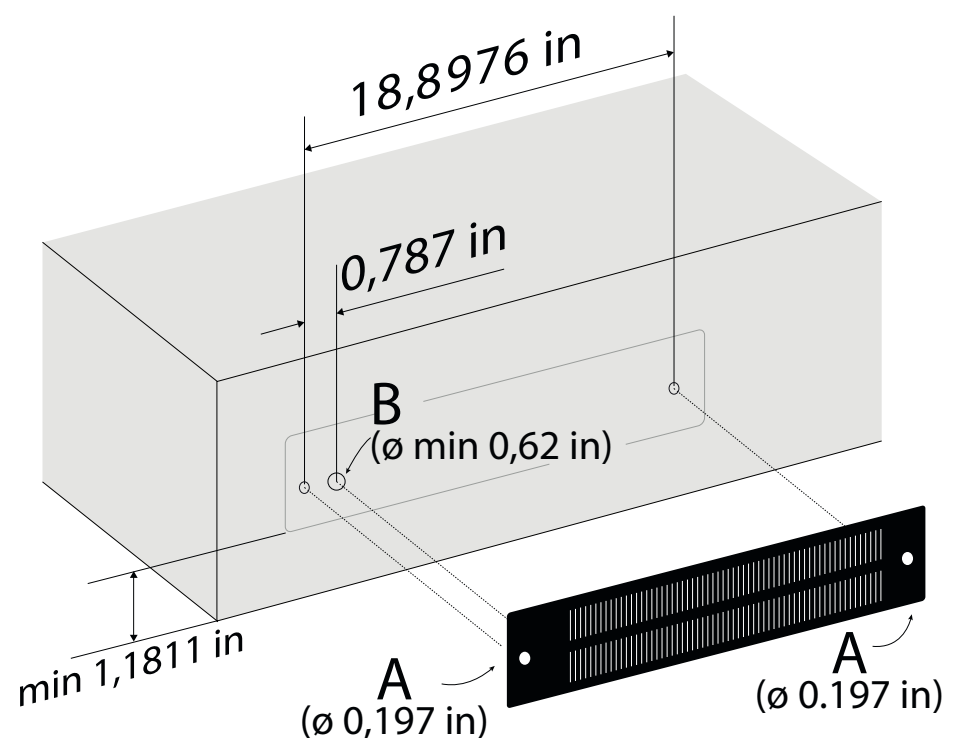

# INSTALLATION (SPB18/22)

4/4



The **SPB18/22 Solar station** can be fixed to the wall using screws and dowels included in the kit. or in any other surface by using 2 screws max diam. 0,1771 in.

The **SPB18/22 Solar station** in a standard installation is naturally oriented at  $25^\circ$  from vertical. If upside-down installed it can be also oriented at  $10^\circ$  or  $45^\circ$  to better capture the solar energy.

**IMPORTANT: Do not go over  $45^\circ$  orientation.**

The panel orientation is made by releasing the side screw (B) having the panel free to rotate. Turn the panel to the allowed angle and tight the screw (B).

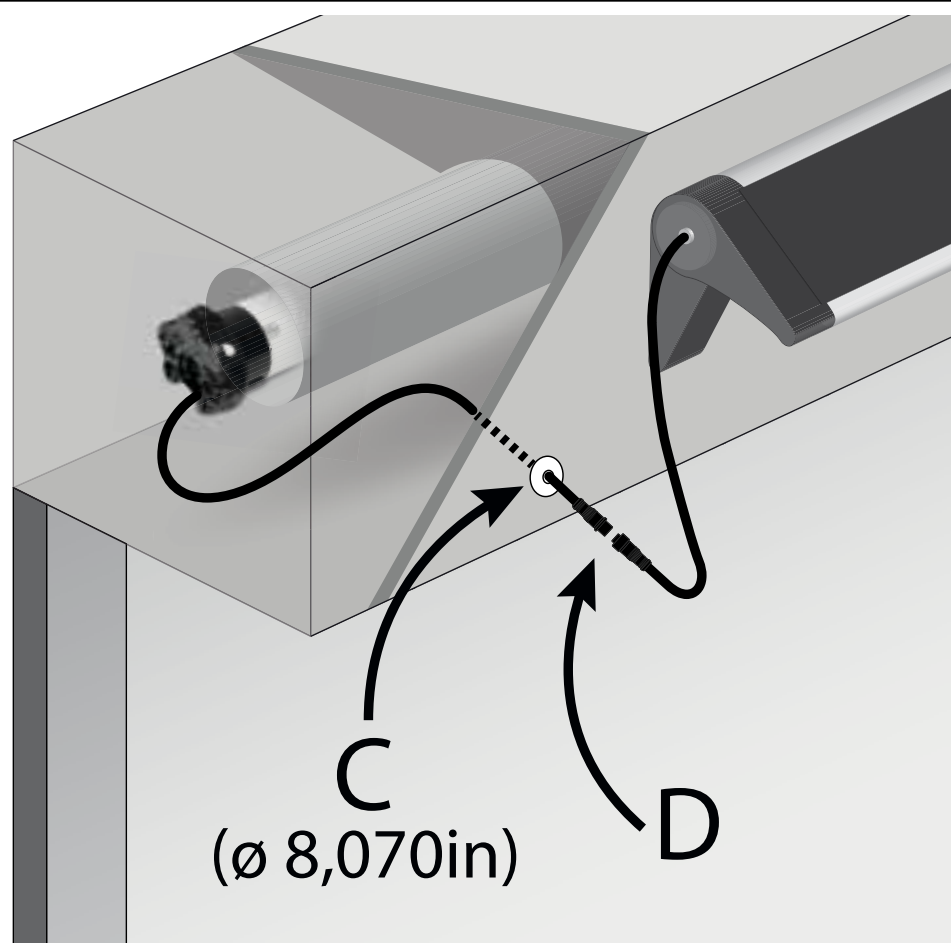
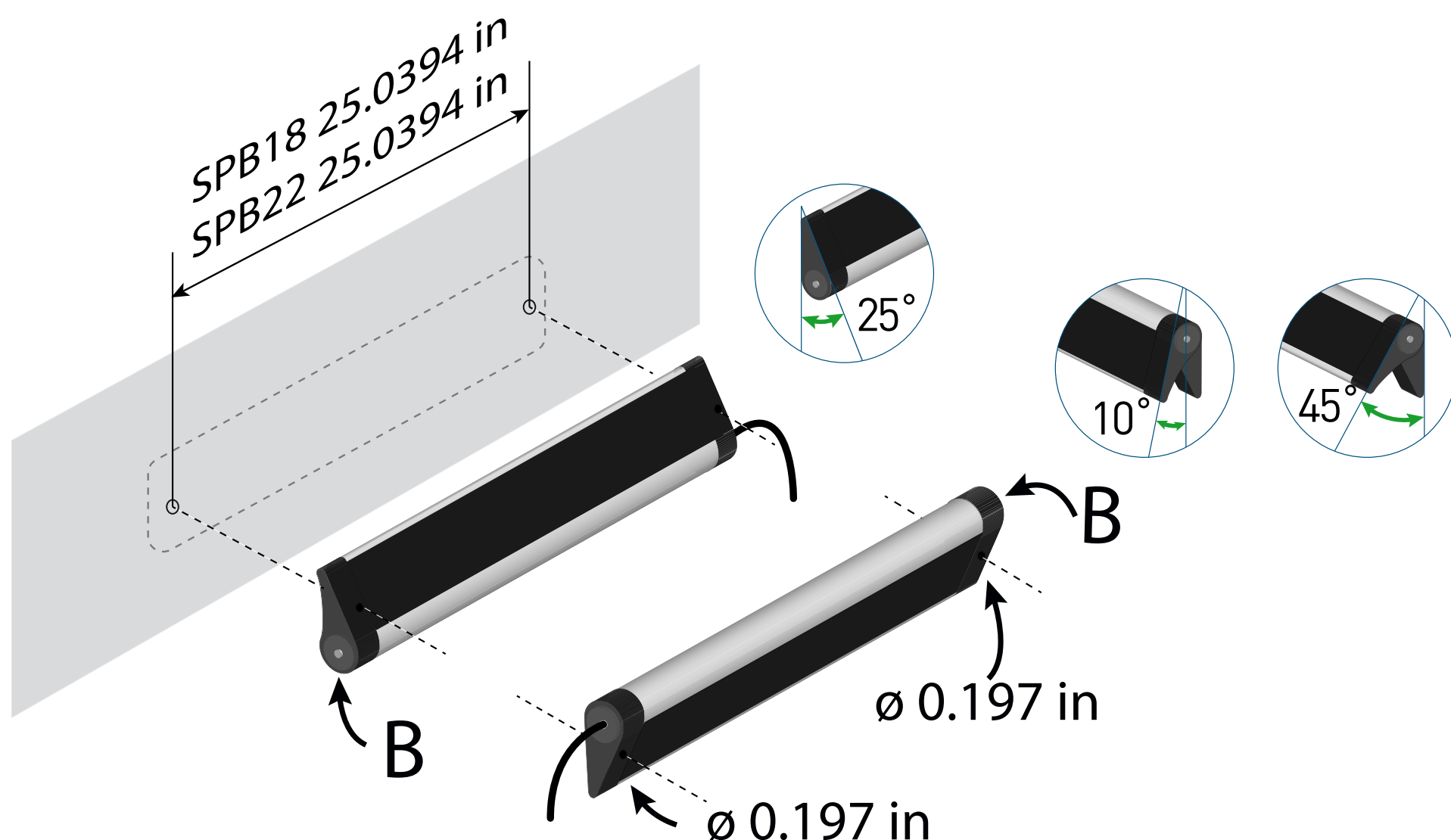

The motor cable is equipped with a cable gland (C) which can be mounted on sheet metal with a thickness of 0,0196 to 0,118 in by drilling a hole  $\varnothing 8,070$  in.

The cable gland is applied from the **inside** of the casing. The panel cable remains outside the cassette, as does the watertight joint (D).

# COMMISSIONING



**IMPORTANT: CHARGE THE BATTERY/SOLAR STATION BEFORE THE INSTALLATION.**

**ATTENTION! THE SOLAR STATION BATTERY, ALTHOUGH IRRADIATED BY THE SUN, IS ONLY CHARGED WHEN CONNECTED TO THE MOTOR.**

**IF DISCONNECTED FROM THE MOTOR, IT CAN ALTERNATIVELY ONLY BE RECHARGED VIA THE BC16NH CHARGER.**

**SOLAR MOTOR KIT version:**

Connect the battery and then the solar panel to the motor cables.

**SOLAR MOTOR KIT WITH SOLAR STATION version:**

Connect the solar station to the motor cable.

**Note: the keyed connectors in all the cables prevent them being connected wrong.**

**ATTENTION: When the connections are made, the motor is live and ready for use.**

**IMPORTANT: IF THERE IS MORE THAN ONE MOTOR TO INSTALL, CONNECT ONE MOTOR AT A TIME KEEPING ALL THE OTHERS DISCONNECTED.**

---

# REPLACING A SOLAR PANEL



A solar panel must be replaced by a professional installer, and only with an identical model. Never throw out the solar panel with domestic waste.

## **SPM18/30 solar panel:**

1. Disconnect the motor cable from the battery.
2. Disconnect the solar panel from the motor cable.
3. Remove the panel cable from the roller shutter casing.
4. Remove the rivets.
5. Remove the solar panel.
6. Install the new solar panel as described in the section above.

## **SPB18/22 Solar station (solar panel + battery):**

1. Disconnect the motor from the energy unit
2. Unscrew the 2 screws which hold the unit.
3. Remove the unit.
4. Install the new unit as described in the section above



## PROGRAMMING TRANSMITTER

CAUTION: If more motors with receiver have to be installed, it is important to power up **only one motor at time** during the first programming session, in order to avoid any interferences with others.

1

Power up the motor to be programmed.

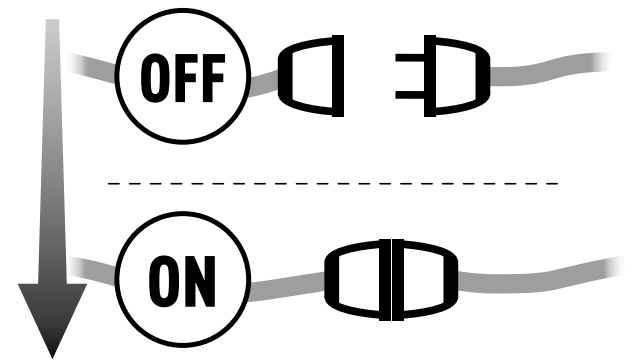

2

Press and hold the PROG-TX button until the motor starts moving.

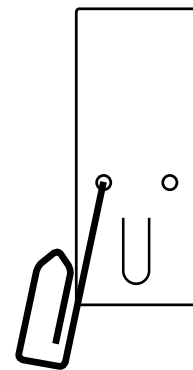

3

Check the rotation of the motor, then release PROG-TX (the motor stops).

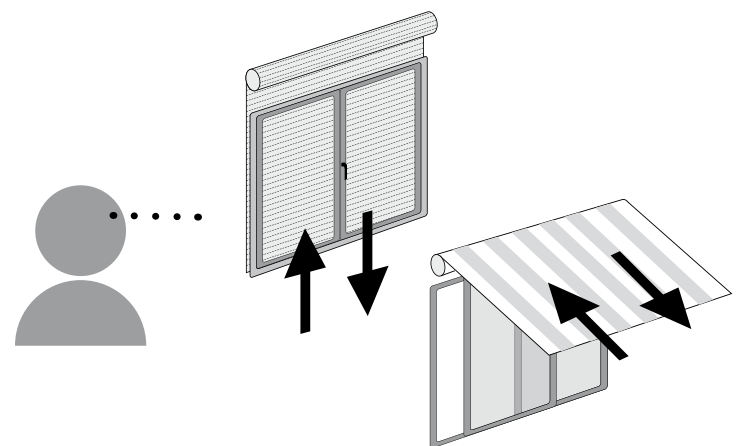

4

Within 5 seconds press the corresponding button (i.e. UP if the motor rotates upwards or DOWN if vice versa).  
The transmitter has been programmed and the rotation of the motor has been synchronized.

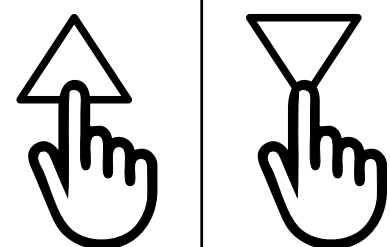



## ADDING TRANSMITTER

1

Press and Hold the PROG-TX button of a transmitter **already paired** until the motor starts moving.

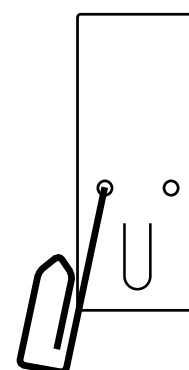

2

Check the rotation of the motor, then release the PROG-TX button (the motor stops).

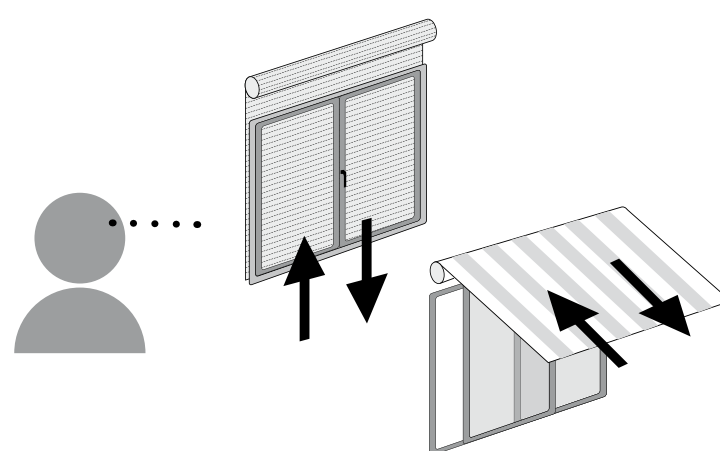

3

Within 5 seconds press the corresponding button (i.e. UP if the motor rotates upwards or DOWN if vice versa) on the **new transmitter being added**.

The new transmitter has been programmed and the rotation of the motor has been synchronized.

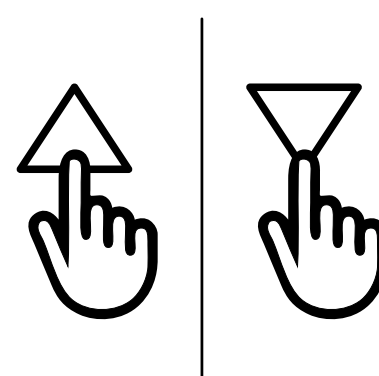



## CHECKING/CHANGING DIRECTION

**IMPORTANT:** change direction must be performed before starting limit setting otherwise limits must be reset.

Press UP or DOWN the motor should go UP or DOWN, otherwise to change direction:

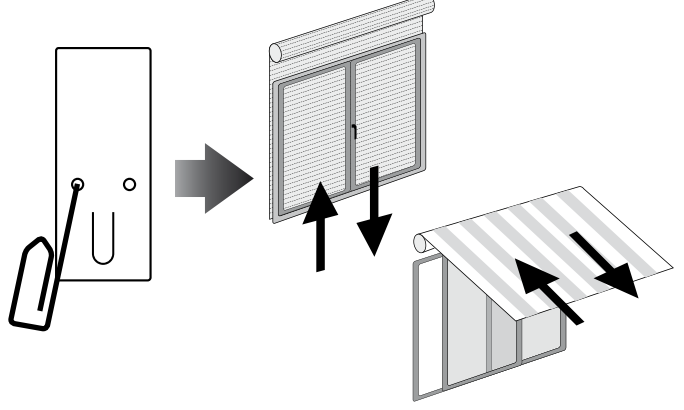
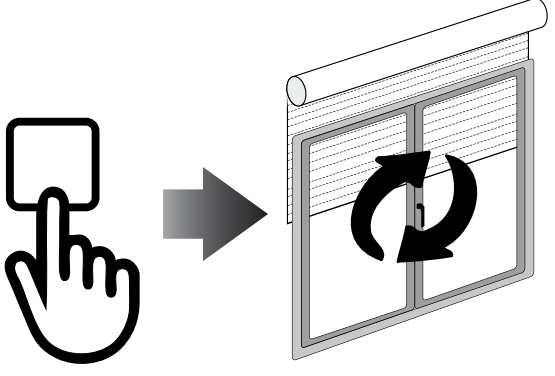
<b>1</b>	Press and hold the PROG-TX button until the motor starts moving	
<b>2</b>	Press STOP: The motor makes a brief jog. Direction of the motor has been reversed.	

## ERASING TRANSMITTER

Push simultaneously the PROG-TX button and STOP of the transmitter until the motor makes a brief movement in both directions.  
Only the transmitter used for this procedure has been deleted from motor memory.

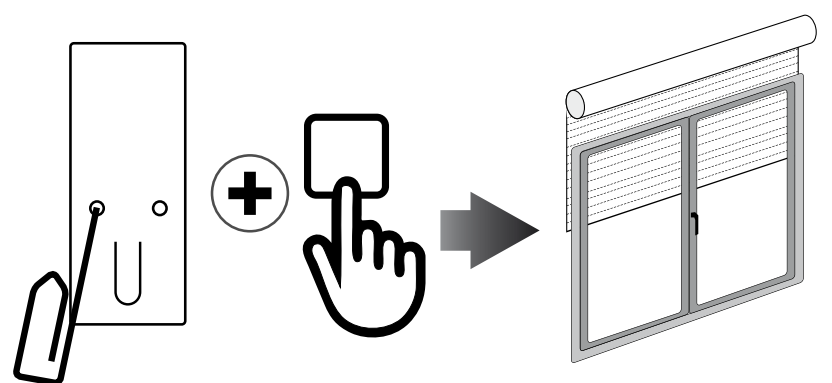



## RESET MOTOR MEMORY

### OPTION 1 - Using an already programmed transmitter

Press and hold both the PROG-TX and STOP buttons until the motor makes first a brief jog and, after a while, a second, long jog. Memory is now empty.

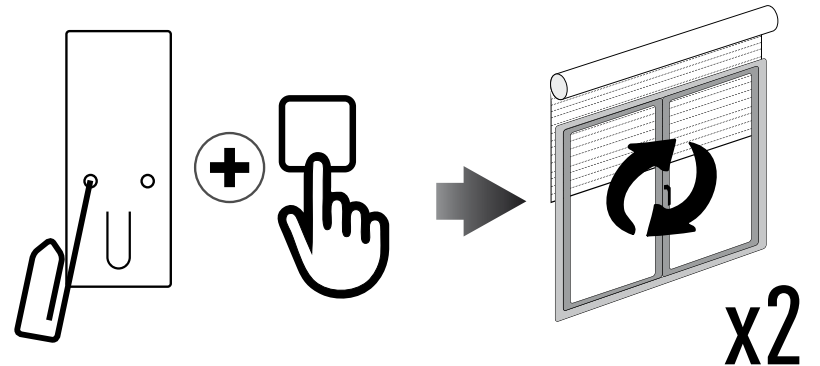

### OPTION 2 - Without an already programmed transmitter

**1**

Switch the motor power supply OFF. Then switch it ON.

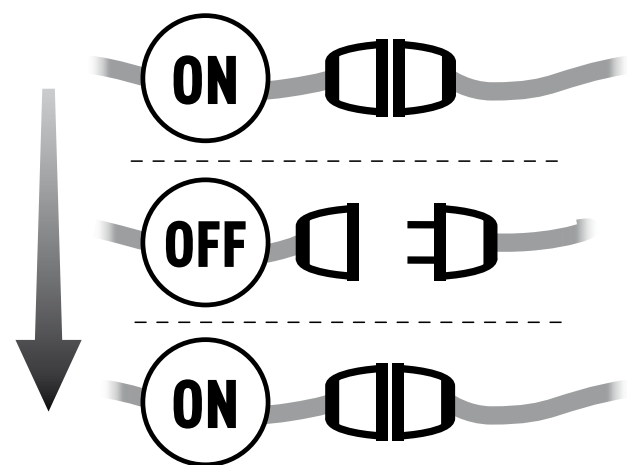

**2**

Within 8 seconds, using any GaposA transmitter, press and hold both the PROG-TX and STOP buttons until the motor makes a long jog. Memory is now empty.

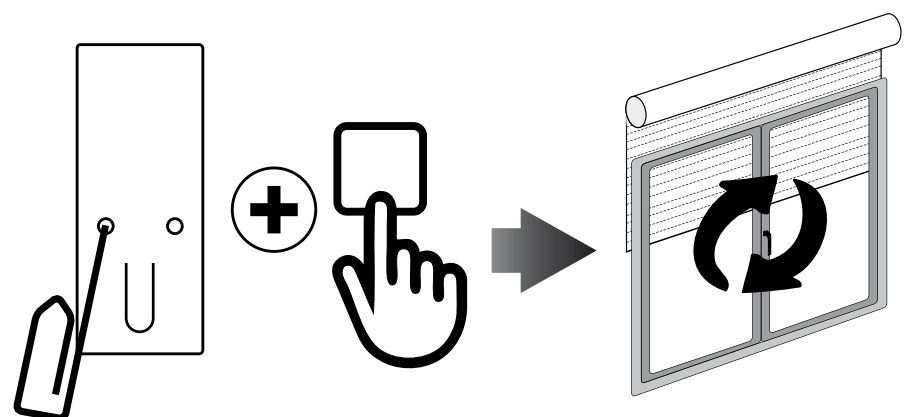



## LIMIT SWITCH SETUP (Just for motors with electronic limit switch) ATTENTION: ALWAYS SET THE UP LIMIT FIRST

<b>1</b>	Push the PROG-FC button until the motor makes a brief jog. <b>Note: during “programming mode” the operations are in “deadman control”</b>	
<b>2</b>	Press and hold the UP button and run the motor to the desired UP limit position.	
<b>3</b>	Press STOP to set the UP limit position. The motor makes a brief jog.	
<b>4</b>	Press and hold the DOWN button and run the motor to the desired DOWN limit position.	
<b>5</b>	Press STOP to set the DOWN limit position. The motor makes a brief jog.	

Note: accurate limit setting can be performed when UPWARD or DOWNWARD by pressing the PROG-FC button a second time. The motor then moves slowly in steps towards the desired limit. Always press STOP button to set the limit position.

# SETTING THE LIMITS INDIVIDUALLY



If the limits need to be changed after the initial limit setting procedure, it is possible to change the limit positions individually. One limit can be set without the other limit needing to be set. The motor can be in any position to initiate the procedure.

**During “limit setting mode” the operations are in “deadman control” (The UP and DOWN buttons must be held DOWN in order to move the motor).**

## TO CHANGE THE UP LIMIT:

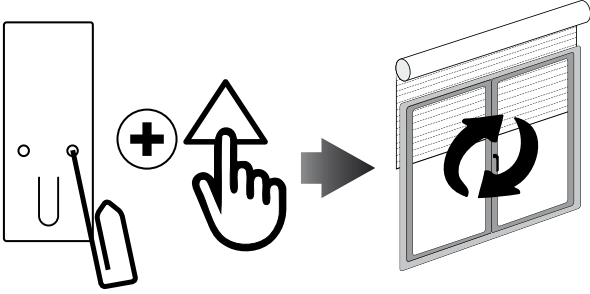
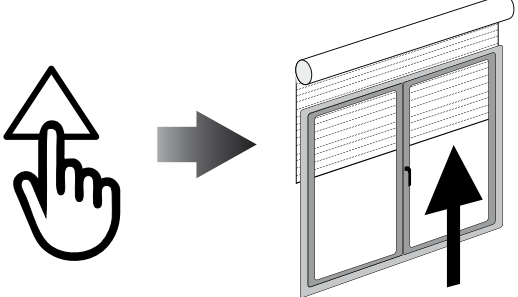
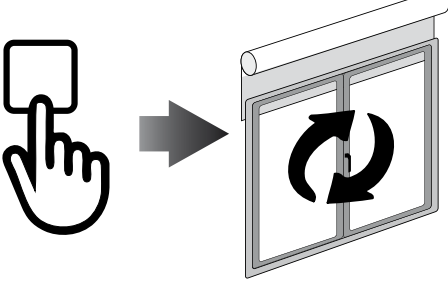
<b>1</b>	From any point between the existing limits, press and hold both the PROG-FC button and the UP button until the motor makes a brief jog.	
<b>2</b>	Press and hold the UP button until the desired new UP limit is reached.	
<b>3</b>	Press the STOP button to set the limit. The motor makes a brief jog to confirm. The new up limit is set.	

# SETTING THE LIMITS INDIVIDUALLY



## TO CHANGE THE DOWN LIMIT:

<b>1</b>	From any point between the existing limits, press and hold both the PROG-FC button and the DOWN button until the motor makes a brief jog.	
<b>2</b>	Press and hold the DOWN button until the desired new DOWN limit is reached.	
<b>3</b>	Press the STOP button to set the limit. The motor makes a brief jog to confirm. The new up limit is set.	

# INTERMEDIATE POSITION



## INTERMEDIATE POSITION SETUP

1

Stop the shutter/awning in the desired intermediate position.

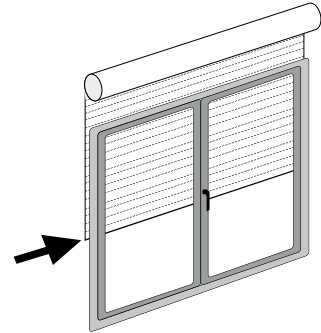

2

Press simultaneously the UP and DOWN buttons until the motor makes a brief movement in both directions. The intermediate position has been setup.

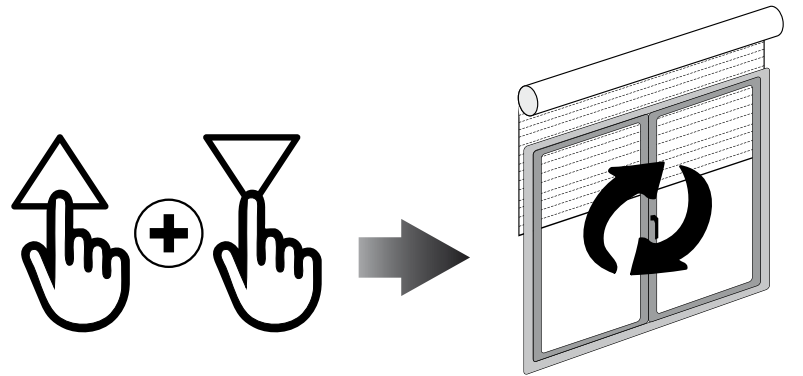

## RECALLING THE INTERMEDIATE POSITION

Keep the STOP button pressed at least for at least 3 seconds.

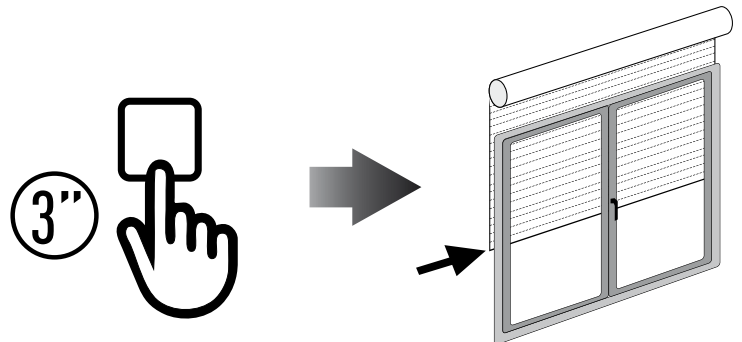

## ERASING THE INTERMEDIATE POSITION

Press simultaneously, both the UP and DOWN buttons until the motor makes a brief movement in both directions.

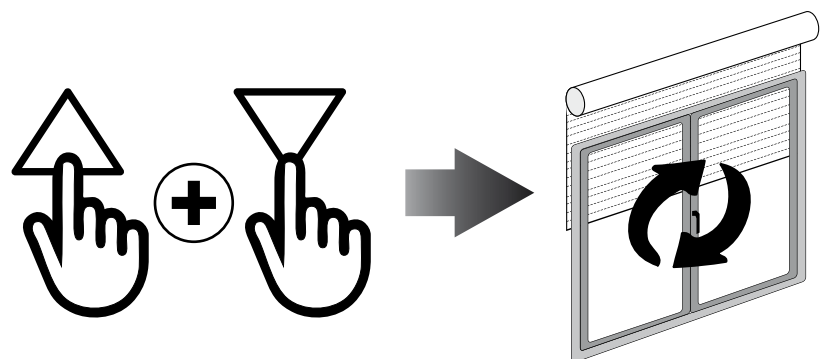



# DEACTIVATING OBSTACLE SENSITIVITY

1/2

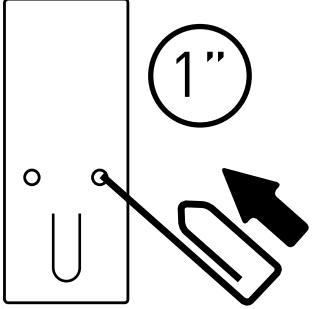

**ATTENTION! All motors are equipped with obstacle detection function. On models 616 and 1012 the feature is disabled as the factory setting.**

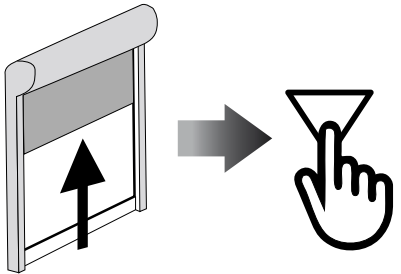
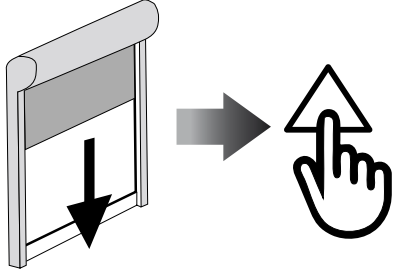
<b>1</b>	Press for 1 second and release PROG-FC button.	
<b>2</b>	Press UP button	
<b>3</b>	As soon as the motor runs upward press DOWN button.	
<b>4</b>	As soon as the motor runs downward press UP button.	



# DEACTIVATING OBSTACLE SENSITIVITY

2/2

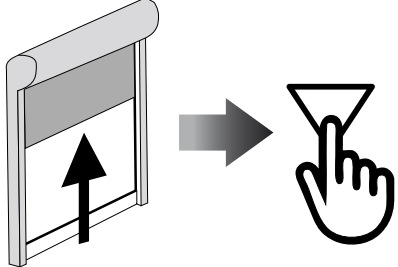
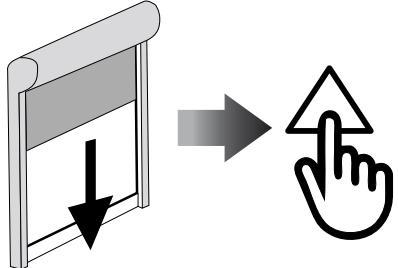
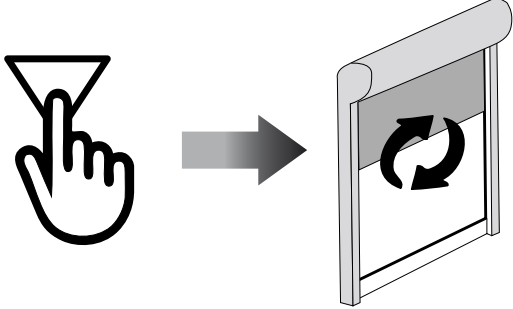

5	As soon as the motor runs upward press DOWN button.	
6	As soon as the motor runs downward press UP button.	
7	When the motor runs upward <b>press and hold</b> DOWN button until you get a jog as confirmation of <b>deactivation</b> .	

## ACTIVATING OBSTACLE SENSITIVITY

Perform the same sequence. At step 7. you get **2 jogs** as confirmation of **activation**.

