

# QC500

DIGITAL CONTROL UNIT FOR 3PHASE MOTORS  
WITH MECHANICAL LIMIT SWITCH

# QC500E

DIGITAL CONTROL UNIT FOR 3PHASE MOTORS  
WITH ELECTRONIC LIMITS SWITCH WITH ENCODER

# QC501

DIGITAL CONTROL UNIT FOR 1PHASE MOTORS  
WITH MECHANICAL LIMIT SWITCH

# QC501E

DIGITAL CONTROL UNIT FOR 1PHASE MOTORS  
WITH ELECTRONIC LIMITS SWITCH WITH ENCODER

Versions **F**  
with emergency STOP



## IMPORTANT SAFETY INSTRUCTIONS

### Specific use

The control unit is specifically for doors moved with a motor.

Safe operation is only guaranteed with normal specific use. The motor must be protected against rain, weather and aggressive environmental conditions.

No liability is accepted for damage caused by other applications or failure to observe the information in the manual.

No modifications are permitted, otherwise the declaration of conformity will be deemed void.

### Safety information

Installation and commissioning must be carried out by trained personnel.

Only technically trained electricians are authorised to work on electrical equipment. They must be able to assess the tasks assigned to them, recognise potential danger zones and be able to implement appropriate safety measures.

Installation must be carried out after disconnecting the general power supply.

Observe existing regulations.

Cover and protect the devices.

Only use with cover and protection devices installed.

Ensure that the seals are correctly positioned and that the cable glands are properly tightened.

**Attention: it is highly recommended to activate the impulsive mode only after having finished programming the control unit. In particular during adjustment of the mechanical limit switches, use the dead man mode.**

When adjusting the encoder limit switches, the control unit will only allow operation in dead man's mode.

### Spare Parts

Use only original spare parts.

## DIRECTIVES

Directives – EMC Directive 2014/30/EU	EN 61000-6-3 (2007) + A1:2011 Emission – Residential EN 61000-6-1 (2007) Immunity – Residential EN 61000-6-4 (2007) Emission – Industry EN 61000-6-2 (2005) Immunity – Industry EN 61000-4-3 (2006) +A1(2008) +A2(2010) RF-field immunity EN 60335-1 (2012)/AC:2014 Safety – Part 1: General requirements
Directive – Low Voltage Directive LVD 2014/35/EU	EN 60335-1 (2012)/AC:2014 Safety of Household and similar electrical appliance/ Part 1. EN335-2-103:2015
TÜV type tested according to:	EN 12453 (2017) Industrial, Commercial and garage doors and gates. Safety in use. EN ISO 13849-1:2015 Safety of machinery

## TECHNICAL DETAILS

Installation	Vertical on a vibration free and flat wall
Temperature range (operating)	-10...+50°C
Humidity	Up to 93% RH non-condensing.
Vibration	Low-vibration installation, wall mounted.
PCB dimension	163 x 225 x 80 mm
Supply voltage:	QC500 400VAC; 50/60 Hz; +/- 10% L1, L2, L3, PE (N optional) 230VAC; 50/60 Hz; +/- 10% L1, L2, L3, PE Mains fuse max: 3 x 10A Rated insulation voltage $U_i = 400V$ QC501 230VAC; 50/60 Hz; +/- 10% L, N, PE
Transformer	Max 13 VA , VDE 0570/EN61558 Primary 230VAC winding is thermal protected by built-in thermal transformer fuse. Both secondary windings are overload protected by multifuses.
Motor output	Max motor load by 3 x 400VAC: 4 kW Max motor load by 3 x 230VAC: 2.3 kW Max motor load by 1 x 230VAC: 1.5 kW Max motor current: 8.5A
Emergency stop, Stop, Thermo spec. door stop and Safety chain	Function as normal stop command and disconnect power to contactor coils
24VDC Output (terminals X3-18,X3-19)	24VDC $\pm$ 20% (non-regulated) Max load: 250mA (T=25°C) Max load: 200 mA (T=40°C) (if no plug-in module is used, else there currents must be subtracted)
Safety edge input	PNE/air switch Electric type - 8k2 termination $\pm$ 10% Optical type Performance level C, Category 2
Optical safety edge	Input voltage high (green): 2.5 - 5.0 Volt. Input voltage low (green): < 0.5 Volt. Input frequency range (green): 250 - 2000 Hz (50% duty-cycle) Pulse interval maximum (green): 7.0 mS (when not 50% dutycycle)
Photo input	X1-1, 2, 3, 4 External photo 1, 24VDC X3-19, 20, 21, 22 External photo 2, 24VDC (e.g. self contain photo cell) Performance level C, Category 2
Electronic limits	RS485, Data+ Data-, terminated with 120 Ohm
Box dimension	210 x 305 x 120 mm

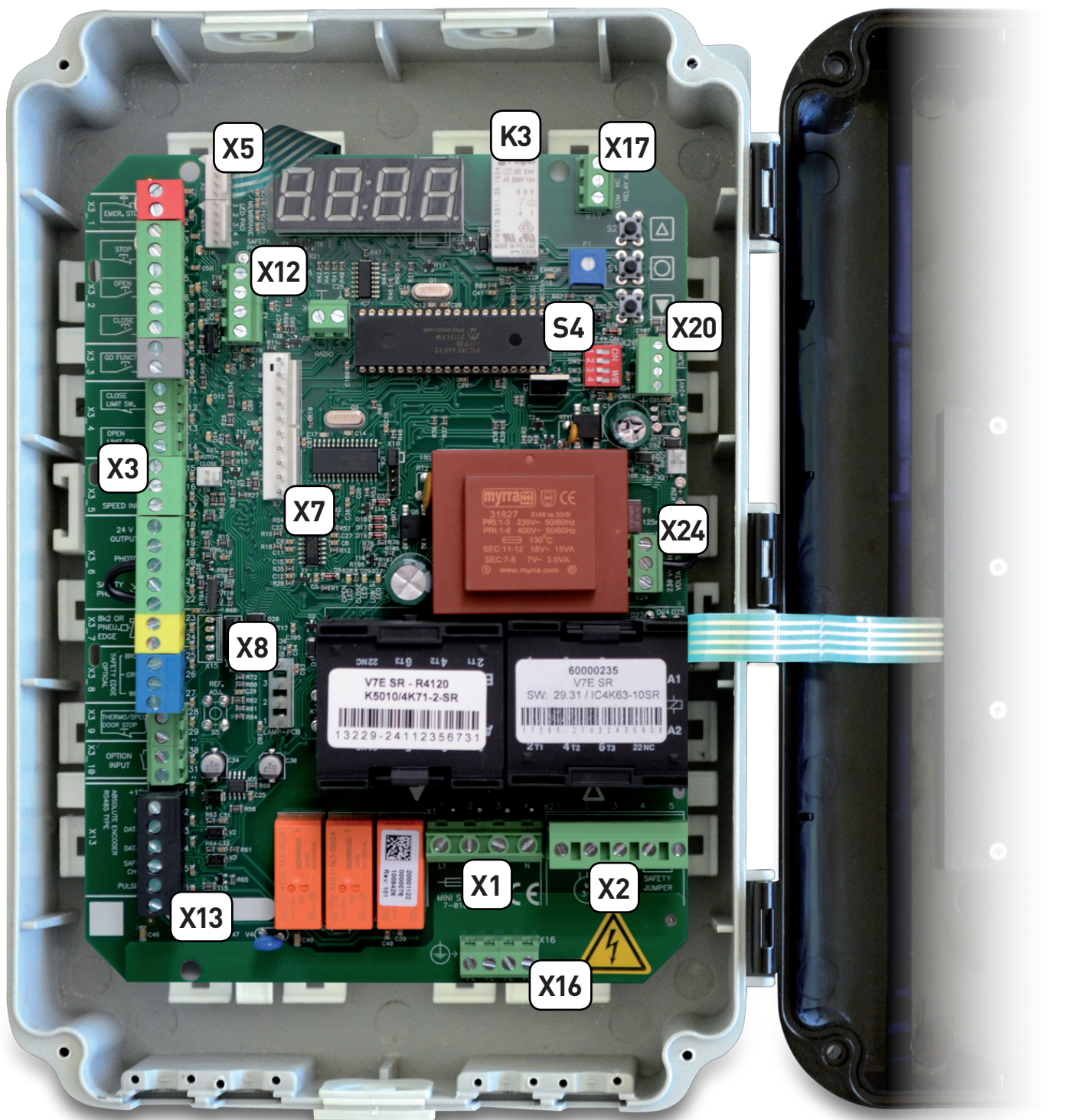

- |            |  |
|------------|--|
| <b>X1</b>  | MAIN SUPPLY TERMINAL (L1, L2, L3, N)                     |
| <b>X2</b>  | PLUG IN CONNECTOR FOR MOTOR (U, V, W)                    |
| <b>X3</b>  | TERMINALS FOR SAFETY DEVICES                             |
| <b>X5</b>  | INTEGRATED PUSHBUTTON                                    |
| <b>X7</b>  | SLOT RADIO MODULE QCMR500 - OPTIONAL                     |
| <b>X8</b>  | TRAFFIC LIGHT LAMP QCLSM - OPTIONAL                      |
| <b>X12</b> | PHOTO CELL 1 TERMINALS (PHOTO 1)                         |
| <b>X13</b> | TERMINALS FOR ABSOLUTE ENCODER                           |
| <b>X16</b> | GROUND TERMINALS ⊕                                       |
| <b>X17</b> | TERMINALS FOR AUXILIARY DEVICES - RELAIS <b>K3</b> (AUX) |
| <b>X20</b> | SECONDARY MOVABLE SAFETY EDGE                            |
| <b>X24</b> | POWER-SELECTION JUMPER 400V / 230V                       |
| <b>S4</b>  | PROGRAMMING MICROSWITCHES                                |

**FIG. 1**

**RADIO RECEIVER MODULE  
ADDITIONAL QCMR500  
ON X7 (OPTIONAL)**

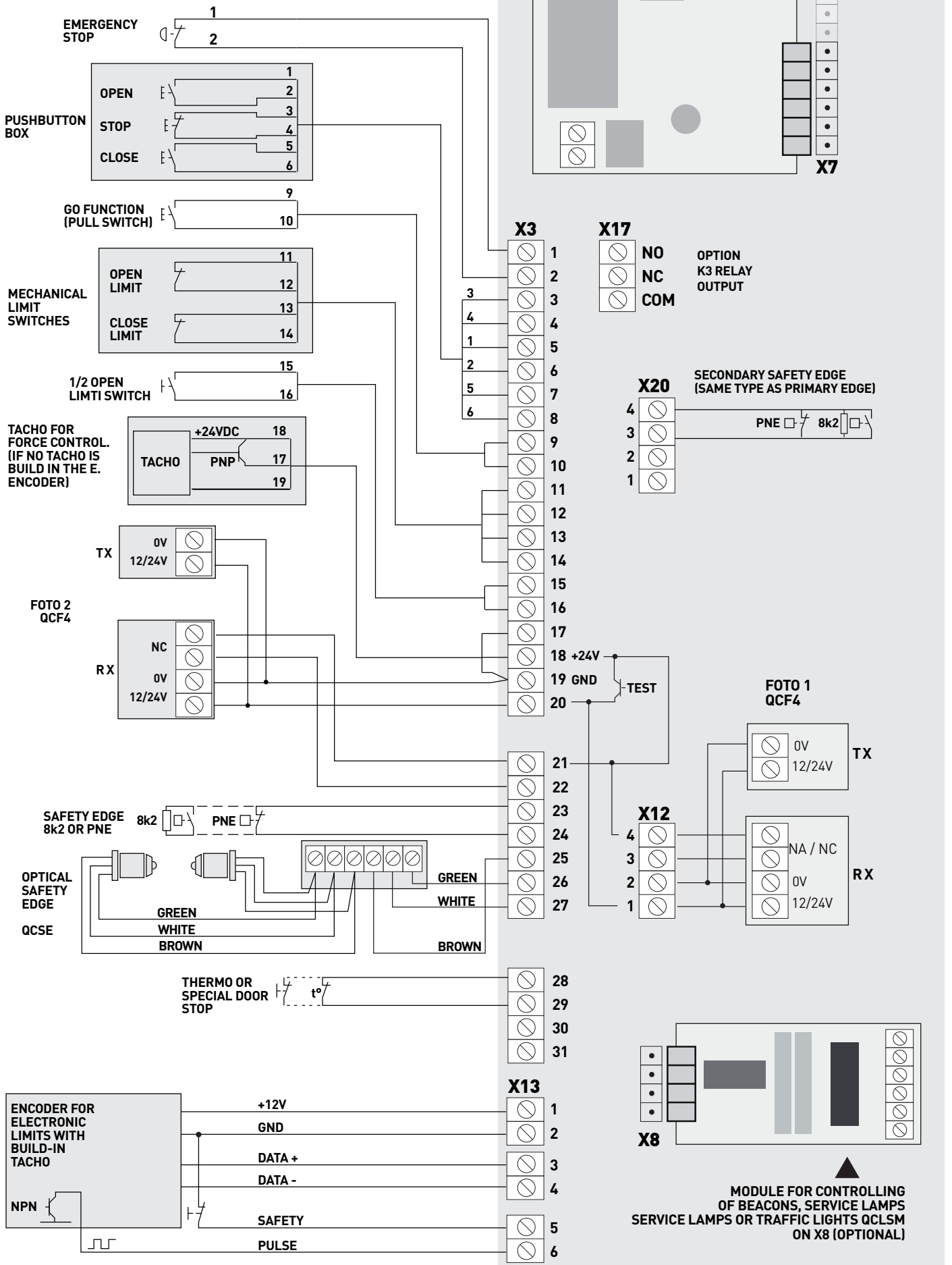

# 1\_ ENCLOSURE INSTALLATION

For a correct installation:

- Install where the control unit can be protected from rain or adverse weather conditions
- Mounting must be vertical
- The surface has to be checked for flatness, slope and freedom from vibrations
- Do not install in an area of potential risk of condensation
- It is important that the door can be clearly seen from the position of the control through its travel
- Install in an area not accessible to children or unauthorized persons
- Do not perform any electrical connections before the enclosure installation is completely accomplished

## 2\_ ELECTRICAL OPERATING INSTRUCTIONS (Read carefully and respect the connection's sequence)

**IMPORTANT! All the connection operations must be performed only after the main power supply has been disconnected. TURN OFF THE MAIN POWER SWITCH BEFORE ANY OTHER OPERATION!**

### 2.1\_ CONTROL UNIT POWER SUPPLY

**WARNING! The installation must include an automatic cut off switch with minimum distance between the contacts of at least 3 mm.**

The control unit can be powered in three different modes: 400V~ 3-phase, 230V~ 3-phase and 230V 1-phase.

The power supply of the motor and of the control unit must correspond (it is not possible for example to power a 400V~ 3-phase motor in case the control unit is set for a 230V~ 1-phase or 3-phase power supply).

**WARNING: if you power a motor with a power mode other than that for which it is set you can damage the motor and the control unit and put at risk the safety of the installer.**

GAPOSA pre-sets the control unit according to the customer requirements in one of the two configurations:

400V~ 3-phase or 230V~ 1-phase and only regarding the internal wiring, providing also the power cable with plug type IEC (red in case of 3-phase and light blue in case of 1-phase).

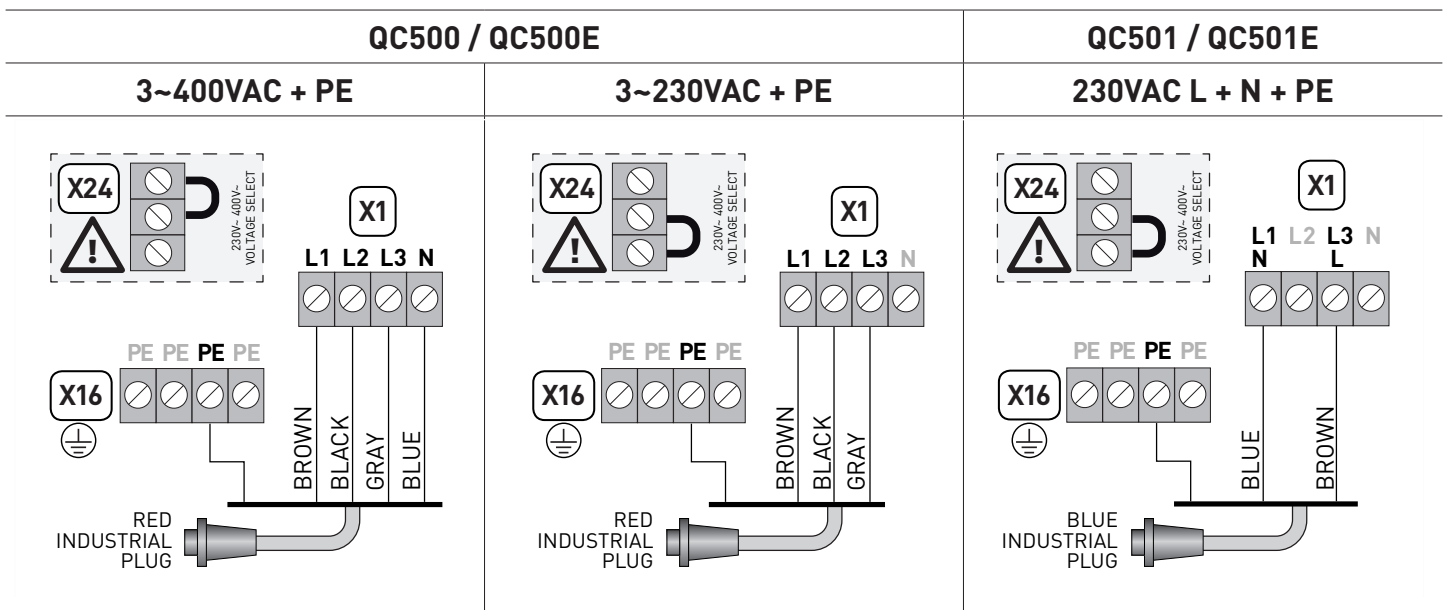

If you need to disconnect the power cable and then to reconnect it or change the control unit wiring sequence, you **HAVE TO** connect the wires properly, restoring the original configuration.

**Take care to connect the ground wire to the X16 terminal.**

**WARNING: if you connect the wires differently from what is shown in the diagrams you can damage the motor and the control unit and endanger the safety of the installer.**

**WARNING! Verify the direction of rotation of the motor supplied with 400V or 230V 3-phase:**

pay attention to the direction of rotation of the motor: by pressing the OPEN button (S2) the door has to open while, by pressing the CLOSE button (S3), the door must close. In case of wrong direction, reverse two of the phases (L1, L2 and L3) on the X1 terminal.

## 2.2\_ CONNECTING THE CONTROL TO THE MOTOR

**IMPORTANT! All the connection operations must be performed only after the main power supply has been disconnected. TURN OFF THE MAIN POWER SWITCH BEFORE ANY OPERATION!**

After the motor and control are fitted they can be connected with a plug-in cable. The cable has plugs on each end for an easy fitting. The plugs for motor and control panel are different and cannot be interchanged.

Here below you will find the power supply diagrams according to the power supply mode 3-phase / 1-phase:

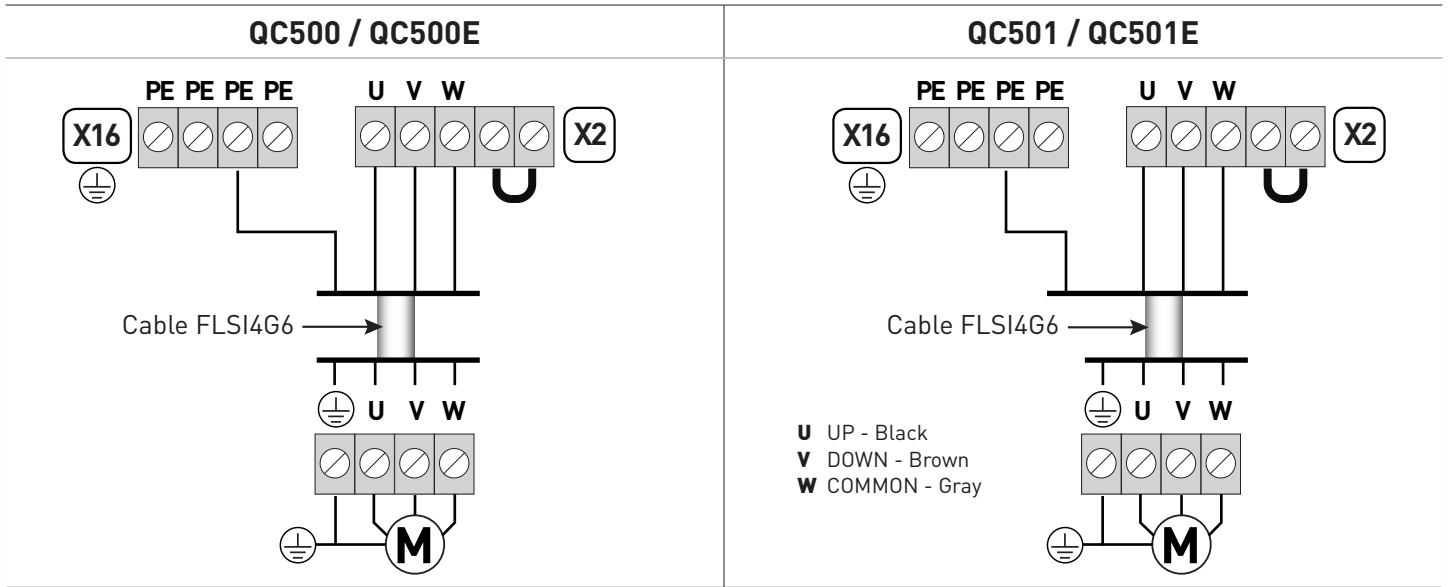

GAPOSA can supply multicore cables power/signal of different lengths with quick plug terminals (cable type FLSI4G).

The power connector must be plugged in the terminal X2 of the control unit. Then you must connect the ground wire to the connector X16. If you have not a plug and play cable you can use the 5-poles connector supplied (on request) with the control unit following the above diagrams.

Follow the instructions carefully in case of a 1-phase motor with regard to the connection of the common pole and of the two directions UP and DOWN. If wrong powered the motor risks to run only in one direction or not run at all.

## 3\_ KEYBOARD

The keyboard on the cover of the control unit is connected to terminal X5 through the flat cable (A): if you need to disconnect the flat and then to reconnect it, pay attention to the direction of connection (reference point B).

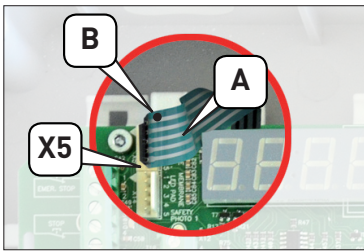

## 3.1\_ EMERGENCY STOP BUTTON

There is an EMERGENCY STOP button on the cover of the F versions.

- Press the button to instantly deactivate all functions of the control unit.
- Turn the button clockwise to reactivate the control unit.

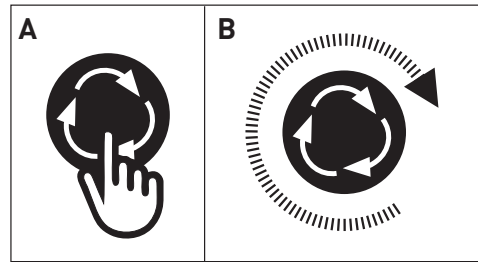

## 3.2 ADDITIONAL CONTROL BUTTONS

You can connect additional control pushbuttons through the terminals from 3 to 8 of the X3.

- connect a normally closed button, eliminating the standard jumper, to the contacts 3 and 4 for the STOP command;
- connect a normally open button to the contacts [5] and [6] for the OPEN command [S2];
- connect a normally open button to the contacts [7] and [8] for the CLOSE command [S3];

**PAY ATTENTION AT THE CONNECTIONS! No line voltage (230V~ or other external devices) can be connected to the buttons otherwise the unit is damaged.**

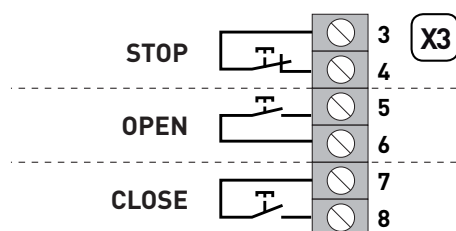

## 4\_ MECHANICAL LIMIT SWITCH (QC500 / QC501)

The control unit is pre-set to the type of limit switch the customer requires when placing the order. Please verify the conformity of the control unit with the motor limit switches type. Make sure that the label on the box indicates:

### LIMIT SWITCH: MECHANICAL

The mechanical limit switch wires are connected according to the diagram of fig. 2.

**ATTENTION: if you connect a control unit pre-set for mechanical limits to a motor with encoder limits, the motor does not perform correctly. In particular, the motor will not find the limit positions and this could put at risk the safety of people and/or things.**

The limit switches connector (1) of the multicore cable must be connected to the male connector (2) of the cable the control unit is provided with (Fig. 2a).

FIG. 2

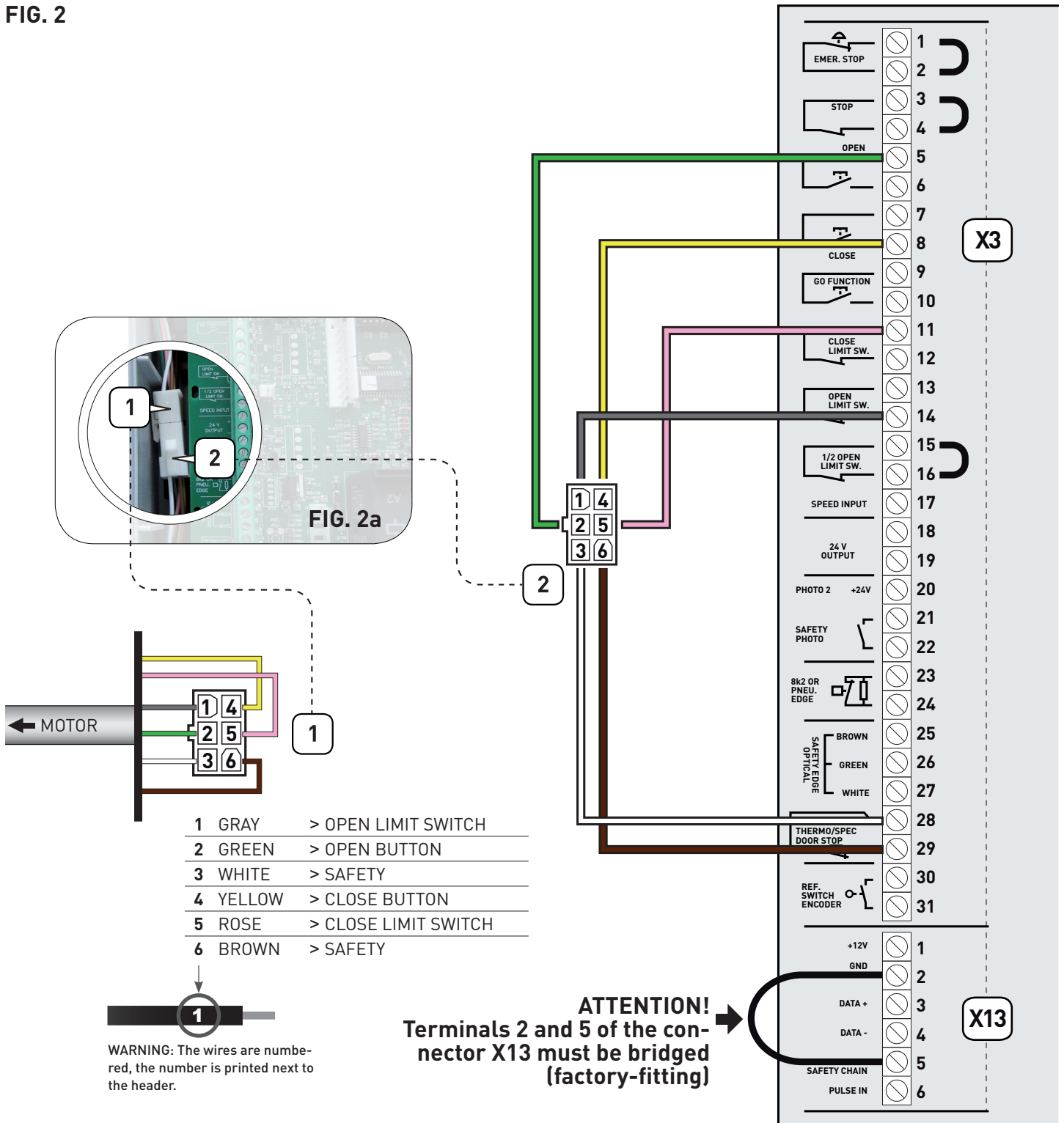

In case you are not using a GAPOSA multicore cable, you have to use a cable with AMP 0172168 connector at both ends and the wires connected at the same sequence in both sides.

## 5\_ ELECTRONIC LIMITS WITH ENCODER (QC500E / QC501E)

The control unit is pre-set to the type of limit switch the customer requires when placing the order. Please verify the conformity of the control unit with the motor limit switches type. Make sure that the label on the box indicates: **LIMIT SWITCH: ENCODER**

The encoder limits switch wires are connected according to the diagram of fig. 3.

**ATTENTION: if you connect a control unit pre-set for mechanical limits to a motor with encoder limits, the motor does not perform correctly. In particular, the motor will not find the limit positions and this could put at risk the safety of people and/or things.**

The limit switches connector (1) of the multicore cable must be connected to the male connector (2) of the cable (art. FLCE31W008) the control unit is provided with (Fig. 3a).

FIG. 3

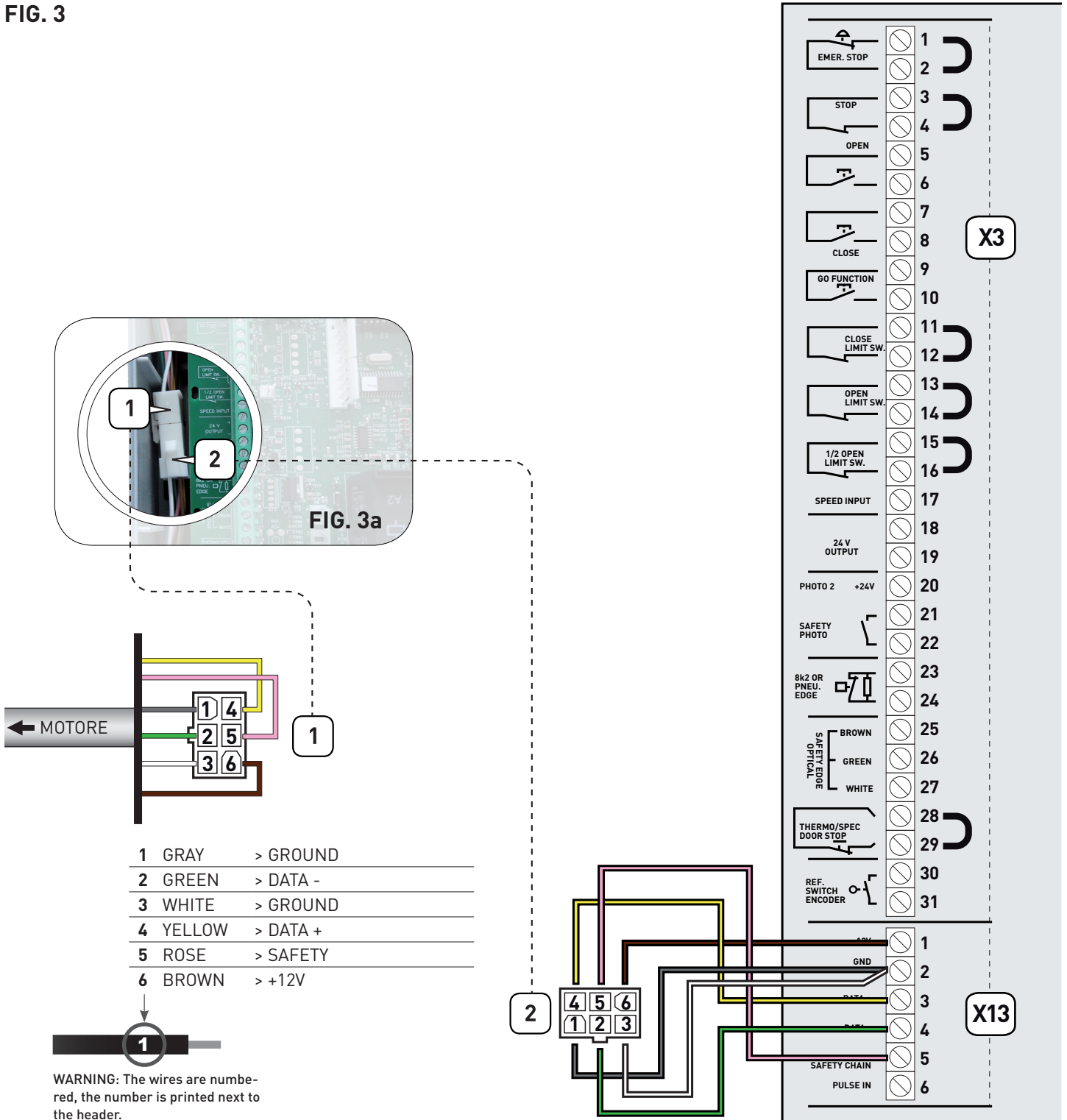

## 6\_ CONTROL UNIT SET-UP

The set-up must be performed with the motor off. Follow carefully the steps as described in the procedures, DO NOT activate any safety, hand controls or radio controls unless specifically requested by the procedure.

Basically the set-up of the control and the right coupling control/motor must be performed by the installer.

### 6.1\_ SET-UP MODE ACTIVATION

To enter the control unit programming mode place the DIP1 of the switch (S4) in ON.

**During set-up the control unit will work only in dead man mode.**

To return to the normal operating mode, place the DIP1 of the switch (S4) in OFF.

### 6.2\_ BASIC PROGRAMMING

The control unit is supplied with a basic setting performed at the factory which can be restored at any time with the reset procedure (see paragraph 7).

Before beginning the programming procedure:

1. Open the cover of the unit
2. Make sure all the connections have been made correctly and that the emergency stop or other safety devices are not activated. Otherwise the display shows the stop symbol active [ ]:
3. Find the buttons OPEN (S2) - CLOSE (S3) - STOP (S1) and the 4 switches (S4) on the board
4. Ensure that the LED D10 is not flashing (in case it flashes, check again point 2)

### 6.3\_ PARAMETER EXPLANATION

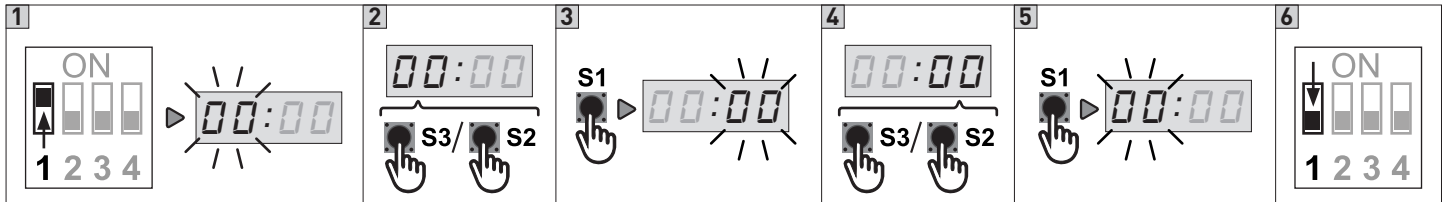

**STOP (S1) button: to switch from PARAMETER field to VALUE field.**

**OPEN (S2) / CLOSE (S3) buttons: to increase or decrease the size of the fields PARAMETER and VALUE**

1. Put DIP switch 1 (S4) in ON position, PARAMETER digits start blinking
2. Select by OPEN (S2) / CLOSE (S3) buttons the number desired
3. Confirm by STOP (S1) button the PARAMETER selected. The VALUE digits start blinking
4. Select by OPEN (S2) / CLOSE (S3) buttons the number desired
5. To confirm the VALUE selected and return to PARAMETER field press STOP (S1) button
6. To leave the set-up mode, place the DIP1 in OFF.

## 7\_ RESET PROCEDURE

The reset procedure allows to erase the settled data of the control unit memory and to return to the default programming.

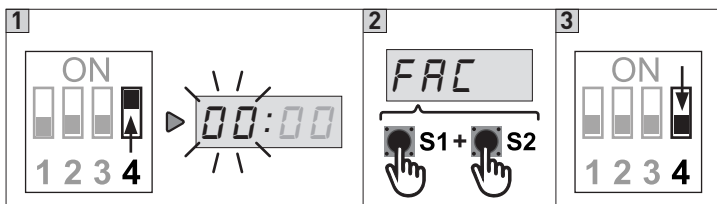

1. Put DIP 4 (S4) to ON position
2. Within 2 seconds press simultaneously the STOP (S1) / OPEN (S2) buttons  
Display will show FAC blinking and the control unit software version number.
3. To leave the set-up mode, place the DIP1 in OFF..

## 8\_ MECHANICAL LIMIT SWITCH

The control unit is factory pre-set for the use of mechanical limit switches [1:00].

So, if you are using a motor with mechanical limit switch you do not have to set any parameter.

Only take care to check the direction of rotation of the motor:



- By pressing the OPEN button (S2), the door must open
- By pressing the CLOSE button (S3), the door must close

Otherwise proceed as described in paragraph "2.2 CONTROL UNIT POWER SUPPLY".

### 8.1\_ MECHANICAL LIMIT ADJUSTMENT

Check that the motor and the control unit are connected as shown in section 4.1, and that the DIP switch S4 is in OFF.

If correctly installed all LEDs are off and the display will show the symbol  which indicates that the motor is positioned between the two limit switches. Check that:

- pressing the UP button the motor moves the door upwards (the display shows: )
- pressing DOWN button the motor moves the door downwards (the display shows: )

### 8.2\_ UP LIMIT SWITCH ADJUSTMENT

Adjust the UP limit switch cam.

When the UP microswitch is pressed, the display will show the symbol  and the LED D14 will switch on.

### 8.3\_ DOWN LIMIT SWITCH ADJUSTMENT

Adjust the DOWN limit switch cam.

When the DOWN microswitch is pressed, the display will show the symbol  and the LED D12 will switch on.

The door will move between the two positions set by the limit switches cams according to the operation mode shown in parameter 01 (see par. 10).

**Warning: the standard mode of the control unit is dead-man (parameter 01). During the mechanical limit switch adjustment use this mode. Refer to section 10 for the other modes of operation.**

## 9\_ SELECTION OF THE DIGITAL LIMIT SWITCH WITH ENCODER (PARAMETER 11)

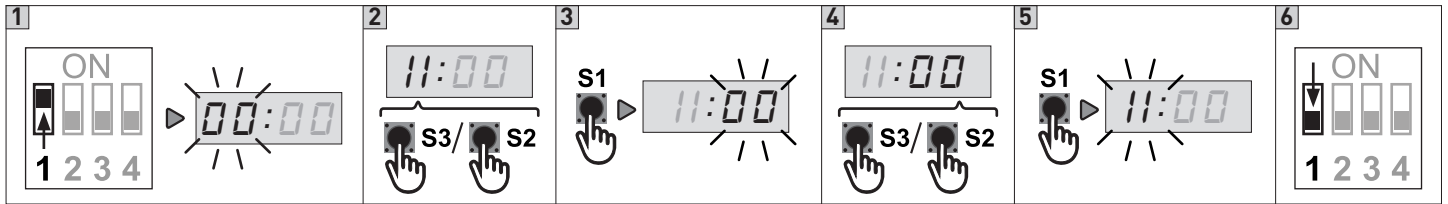

1. Put DIP 1 (S4) in ON position, PARAMETER digits start blinking

2. Select by OPEN (S2) / CLOSE (S3) buttons the number 11

3. Confirm by STOP (S1) button the PARAMETER selected. The VALUE digits start blinking

Depending on the engine GAPOSA used, select by OPEN (S2) / CLOSE (S3) buttons the VALUE:

- Value 00: Mechanical limits
- Value 01: Not in use
- Value 02: Not in use
- Value 03: Not in use
- Value 04: Not in use
- **Value 05: Encoder limits - clockwise rotation (considering the standard phase connection sequence)**  
**BRD18012 / 25012M**  
**RAPIDO 50180/40130/60130/6090/7045**  
**BHS/BBS 50/70/100/120**
- **Value 06: Encoder limits - anticlockwise rotation (considering the standard phase connection sequence)**  
**BRD25012T**  
**SIDONE MIDI LP40014/55012/65012/25060/45035 / SIDONE MAXXI 75015/100010/14008/18006**  
**RAPIDO 9090/12045/120140/18090**

4. To confirm the VALUE selected and return to PARAMETER digits press STOP (S1) button

5. To leave the set-up mode, place the DIP1 in OFF.

 **WARNING: AFTER THE SELECTION OF THE ENCODER LIMIT SWITCH, IT IS NECESSARY TO PROCEED WITH THE LIMIT SWITCHES ADJUSTMENT (SEE SECTION 9.1).**

**Important: please follow the installation requirements of the GAPOSA motors. For example, if an encoded motor is installed in a way which the encoder direction is reversed, it will not run correctly and may put at risk things and/or people.**

**GAPOSA disclaims any responsibility from the consequences of an installation not accomplished according to this policy.**

## 9.1\_ ENCODER LIMIT SWITCH

Check that motor and control unit are connected as shown in section 5.

By following the instructions in section 6.2, select the parameter 11 to the value 05 or 06 **depending on the engine GAPOSA used**.

In this case the D15 LED will flash 2 times until both limit switches are not set.

In case the LED D15 blinks only one time, it is necessary to check the correct connection between encoder and control unit and that the correct limit switch type selecting procedure has been accomplished as shown in paragraph 8.1 including the shutdown of the unit after the selecting step in the case of standard GAPOSA encoder.

### Note:

- the **INTERMEDIATE POSITION** function cannot be activated during programming (parameter 16) - Paragraph 16;
- the **additional photocell on the door frame** cannot be active during programming (parameter 31);
- When you change the limit switch positions the operating time (parameter 51) will be reset to the factory default settings.

## 9.2\_ UP LIMIT SWITCH ADJUSTMENT (PARAMETER 12)

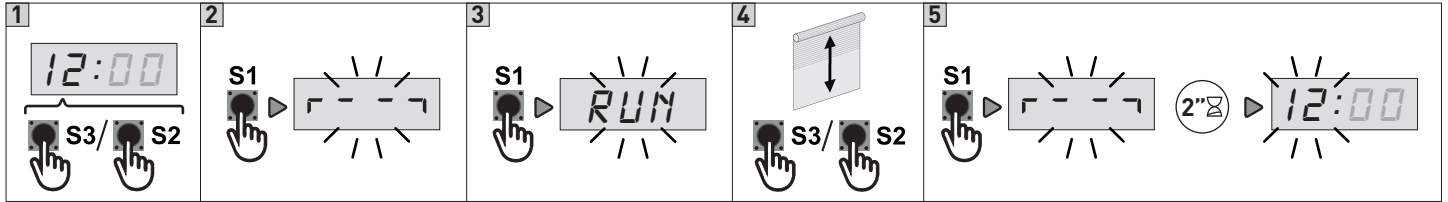

1. Following the PARAMETERS and VALUES management procedure described in Section 6.3, select the PARAMETER 12
2. Press STOP (S1) then the display shows the flashing symbol
3. Press button STOP (S1) once again and the unit, showing the message **RUN** is ready to move the door
4. Use buttons OPEN (S2) and CLOSE (S3) to reach the exact UP limit position.
5. Press the STOP button (S1) to confirm the position. The display will show the symbol for 2 seconds and then the PARAMETER field will start flashing again (showing the number 12).

**To leave the set-up mode, place the DIP1 in OFF.**

## 9.3\_ DOWN LIMIT SWITCH ADJUSTMENT (PARAMETER 14)

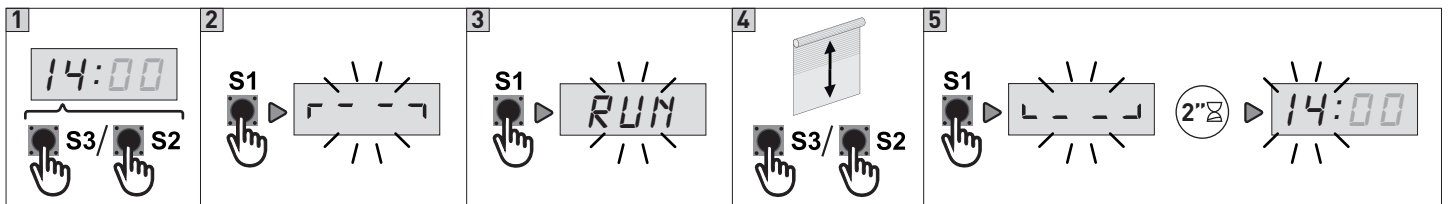

1. Following the PARAMETERS and VALUES management procedure described in Section 6.3, select the PARAMETER 14
2. Press STOP (S1) then the display shows the flashing symbol
3. Press button STOP (S1) once again and the unit, showing the message **RUN** is ready to move the door
4. Use buttons OPEN (S2) and CLOSE (S3) to reach the exact DOWN limit position.
5. Press the STOP button (S1) to confirm the position. The display will show the symbol for 2 seconds and then the PARAMETER field will start flashing again (showing the number 14).

**To leave the set-up mode, place the DIP1 in OFF.**

Once the programming phase is correctly accomplished, the LED D15 stops flashing.

**If the LED D15 continues flashings with a sequence of 2 flashes the limit switches are not duly set.**

Once the limits are set, to tune only one of the two limit positions go to the single parameter 12 or 14 as previously explained.

If the LED D15 shows a sequence of 4 flashes it means that an incorrect encoder direction of rotation has been entered in parameter 11. Change the value of parameter 11 by choosing the opposite direction of rotation according to paragraph 8.1. Once the value changed, start with the limit switch adjustment procedure once again.

## 9.4\_ UP LIMIT SWITCH POSITION TUNING (PARAMETER 13)

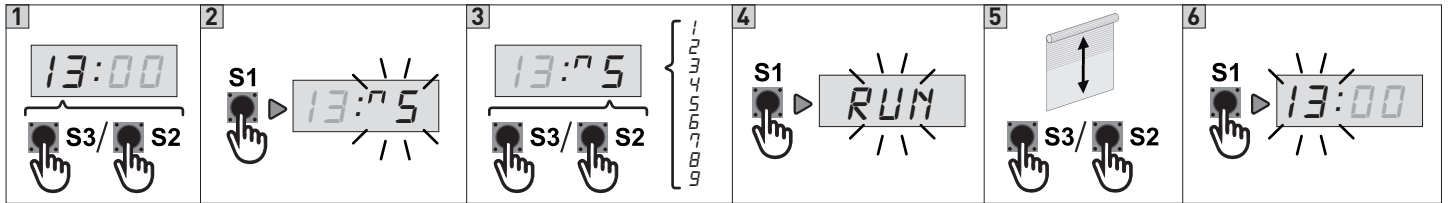

1. Following the PARAMETERS and VALUES management procedure described in Section 6.3, select the PARAMETER 13
2. Press STOP (S1). Display shows symbol flashes
3. Using the buttons OPEN (S2) and CLOSE (S3) vary the value:
  - Value from 4 to 1: progressively decrease the UP position
  - Value from 6 to 9: progressively increase the UP position.

The adjustment range is max  $\pm 0.8\%$  of the travel of the door.  
If the value is not to be changed you can return to the field PARAMETER pressing the STOP button (S1)
4. After modifying the VALUE press the STOP button (S1) to confirm: the display will show
5. You can test the varied position of the door by moving it through the buttons OPEN (S2) and CLOSE (S3).
6. Press the STOP button (S1) to confirm the tuning and return to the PARAMETER field.
7. **To leave the set-up mode, place the DIP1 in OFF.**

## 9.5\_ DOWN LIMIT SWITCH POSITION TUNING (PARAMETER 15)

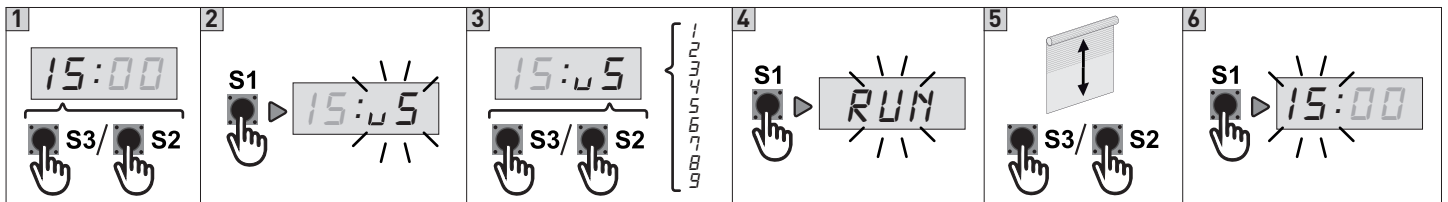

1. Following the PARAMETERS and VALUES management procedure described in Section 6.3, select the PARAMETER 15
2. Press STOP (S1). Display shows symbol flashes
3. Using the buttons OPEN (S2) and CLOSE (S3) vary the value:
  - value from 4 to 1: progressively decreases the DOWN position
  - value of 6 to 9: progressively increases the DOWN position.

The adjustment range is max  $\pm 0.8\%$  of the travel of the door.  
If the value is not to be changed you can return to the field PARAMETER pressing the STOP button (S1)
4. After modifying the VALUE press the STOP button (S1) to confirm: the display will show
5. You can test the varied position of the door by moving it through the buttons OPEN (S2) and CLOSE (S3).
6. Press the STOP button (S1) to confirm the tuning and return to the PARAMETER field.
7. **To leave the set-up mode, place the DIP1 in OFF.**

## 9.6\_ DELAY TIME INDICATION OF MISSING ENCODER POSITION (PARAMETER 81)

Display shows after pre-set operation time without change of encoder position.  
Failure can be reset by hold-to-run steps to find both end limits or relearning of limits

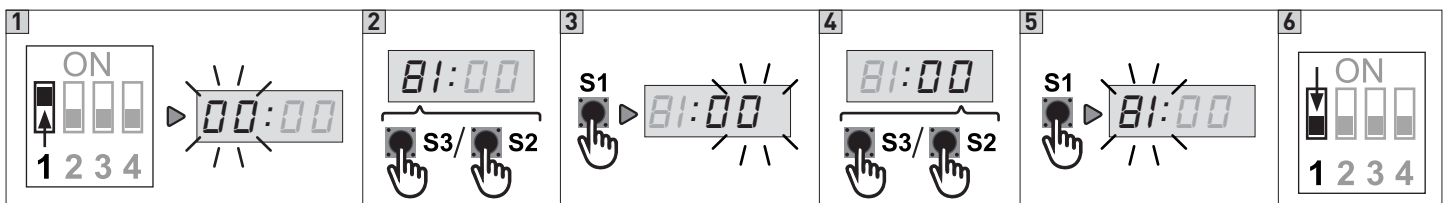

1. Put DIP 1 (S4) in ON position, PARAMETER digits start blinking
2. Select by OPEN (S2) / CLOSE (S3) buttons the number 81
3. Access the field VALUE pressing STOP (S1). The VALUE digits start blinking
4. Using the buttons OPEN (S2) and CLOSE (S3) vary the value
  - Value 00: 1 sec.
  - Value 01: 2 sec.
  - Value 02: 4 sec.
  - Value 03: 4 sec. After operation without change of encoder position the door will stop and error code will be automatically reset. ATTENTION: no limit monitoring by selecting value 03
5. Press the STOP button (S1) to confirm the tuning and return to the PARAMETER field.
6. **To leave the set-up mode, place the DIP1 in OFF.**

## 10\_ OPERATION MODE (PARAMETER 01)

The control unit is pre-set in dead-man control mode (PARAMETER 01, Value 01).

It is possible, however, to define different working modes by modifying the value of PARAMETER 01:

01:01	Hold-to-run OPEN Hold-to-run CLOSE (Put a bridge in X3 terminal 23-24 when there is no safety device)
01:02	Impulsive OPEN Hold-to-run CLOSE (Put a bridge in X3 terminal 23-24 when there is no safety device)
01:03	Impulsive OPEN; Impulsive CLOSE. REQUIRED WITH RADIO MODULE QCMR500-OPTIONAL.
01:04	Not in use

**Warning: it is highly recommended to activate the impulsive mode only after having completed the set-up and adjustments of the control unit. In particular, during the mechanical limit switches adjustment select always the dead-man operation mode.** During the encoder limit switches set-up the control unit will only allow the dead-man working mode.

## 11\_ WORKING TIME SET-UP (PARAMETER 51)

PARAMETER 51 defines the working time of the door.

**WARNING! The default parameter is the 51:02 that is to say a working time of 40 seconds**

To turn off or modify the working time, follow this procedure:

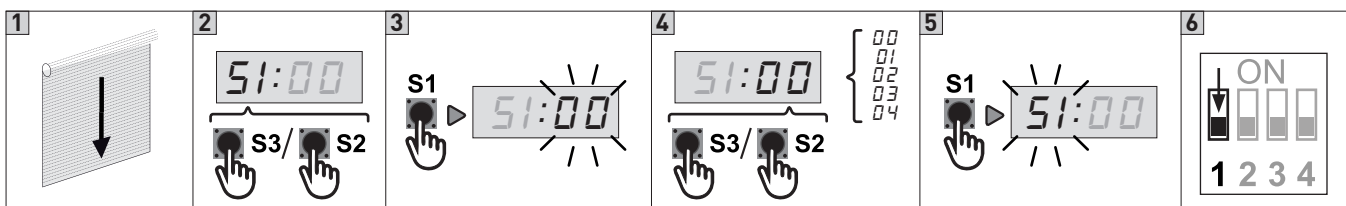

1. Close the door and stop at the DOWN limit position.
2. Following the PARAMETERS and VALUES management procedure described in Section 6.3, select the PARAMETER 51
3. Access the field VALUE pressing STOP (S1). The VALUE digits start blinking
4. Using the buttons OPEN (S2) and CLOSE (S3) vary the value  
 value 00: Function inactive  
 value 01: Working time 20 seconds  
 value 02: Working time 40 seconds (default)  
**value 03: Activate the self learning function to determine the working time (See 11.1).**  
**Caution: In order to use this function the limit switches must be already adjusted.**  
 value 04: Working time 60 seconds
5. Press the STOP button (S1) to confirm the tuning and return to the PARAMETER field.
6. To leave the set-up mode, place the DIP1 in OFF.

**By selecting a working time, the control unit verify if the door moving time exceeds the predetermined value: if this happens the door will stop and the display will shows the error code `E:03`.**

### 11.1\_ RUN TIME CONTROL - AUTOMATIC LEARNING

**Both limits must be set before selecting automatic run time**

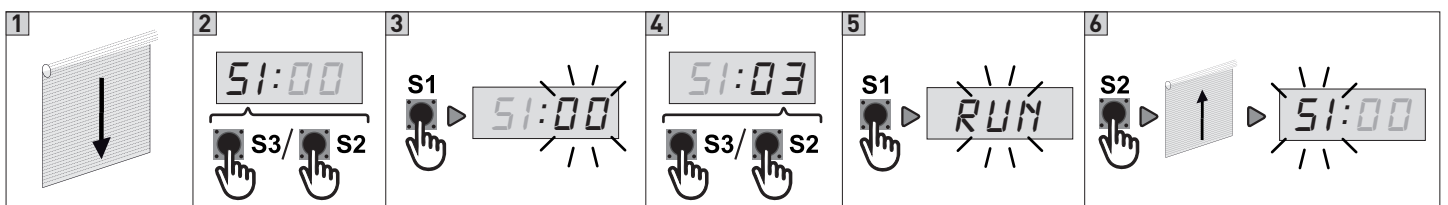

1. Close the door and stop at the DOWN limit position.
2. Following the PARAMETERS and VALUES management procedure described in Section 6.3, select the PARAMETER 51
3. Access the field VALUE pressing STOP (S1). The VALUE digits start blinking
4. Using the buttons OPEN (S2) and CLOSE (S3) select the value 03
5. Press STOP (S1) to confirm. The control unit, showing `RUN` is ready to move the door
6. Using the OPEN button (S2) move the door from the closed position to the open position without interruptions.  
 Once the UP limit switch is reached, the door stops, `RUN` stops flashing and the display will automatically return to field PARAMETER.

**To leave the set-up mode, place the DIP1 in OFF.**

## 12\_ AUTOMATIC CLOSING (PARAMETER 32)

Parameter 32 allows the selection of the door automatic closing after a selectable period of time.

**Important: parameter 32 is visible and accessible only if parameter 01 has been set in impulsive mode**

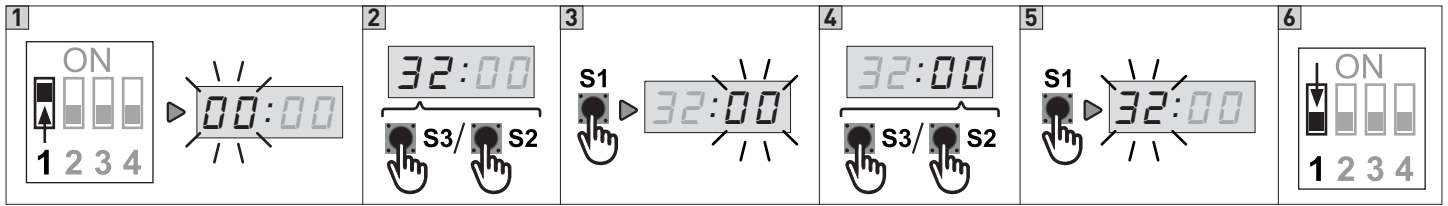

1. Put DIP 1 (S4) in ON position, PARAMETER digits start blinking
2. Using the buttons OPEN (S2) and CLOSE (S3) select the PARAMETER 32
3. Access the field VALUE pressing STOP (S1). The VALUE digits start blinking
4. Using the buttons OPEN (S2) and CLOSE (S3) vary the value

- The value 00 in the field VALUE inhibits the automatic closing;

- A value greater than 0, from 1 to 990, indicates the number of seconds to wait before the activation of the automatic closing:

**NOTE: From 0 to 99 the change is made every second by using the buttons OPEN and CLOSE.**

**Over 99 the change is made every 10 seconds and the value will flash quickly: for example, the VALUE 18 corresponds to 180 seconds, the value 19 to 190 seconds ...**

**If you keep the OPEN button pressed you will get a fast increase of the value**

5. Press STOP (S1) to confirm

6. To leave the set-up mode, place the DIP1 in OFF.

**Warning: the interlock function prevents the automatic closing when activated. For details see section 11 (INTERLOCK)**

## 13\_ CAR WASH FUNCTION (PARAMETER 33)

Count down of auto closing time starts, only if photo has been activated more than "photo active time". Door shall be complete closed before start of a new cycle.

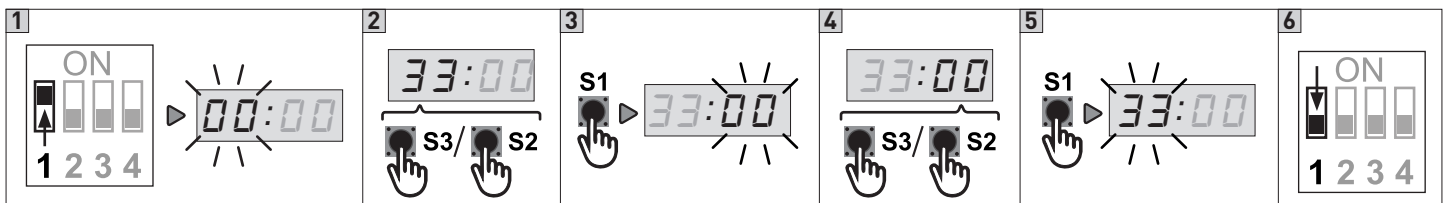

1. Put DIP 1 (S4) in ON position, PARAMETER digits start blinking
2. Using the buttons OPEN (S2) and CLOSE (S3) select the PARAMETER 33
3. Access the field VALUE pressing STOP (S1). The VALUE digits start blinking
4. Using the buttons OPEN (S2) and CLOSE (S3) vary the value

- Value 00: No car wash function

- Value 01: Photo active time in 0,1 sec. Units (e. g. 15 = 1,5 sec.) (Adjustable 1 – 30 units – 0,1 sec. to 3,0 sec.)

5. Press the STOP button (S1) to confirm the tuning and return to the PARAMETER field.

6. To leave the set-up mode, place the DIP1 in OFF.

## 14\_ "FORCED" CLOSING (PARAMETER 34) Only when car wash function is selected in parameter 33

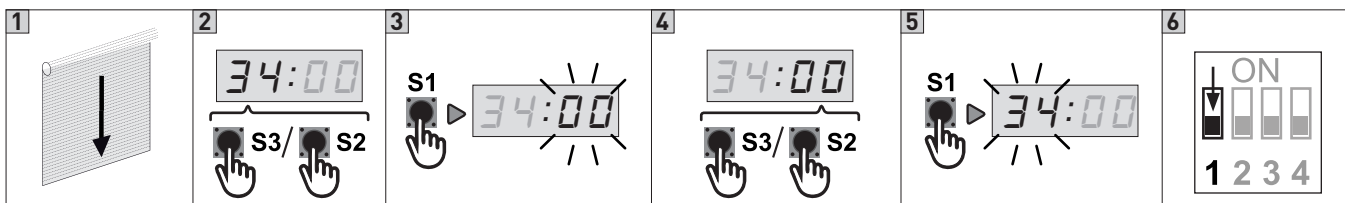

1. Close the door and stop at the DOWN limit position.
2. Following the PARAMETERS and VALUES management procedure described in Section 6.3, select the PARAMETER 34
3. Access the field VALUE pressing STOP (S1). The VALUE digits start blinking

Using the buttons OPEN (S2) and CLOSE (S3) vary the value

- Value 00: No forced closing

- Value 01: Forced closing after 2 min. (even though photo has not been activated)

- Value 02: Forced closing after 5 min. (even though photo has not been activated)

- Value 03: Forced closing after 10 min. (even though photo has not been activated)

- Value 04: Forced closing after 20 min. (even though photo has not been activated)

4. Press the STOP button (S1) to confirm the tuning and return to the PARAMETER field.

5. To leave the set-up mode, place the DIP1 in OFF.

## 15\_ INTERLOCK (PARAMETER 36)

The Interlock function stops the automatic closing if activated, to prevent a closing of the door.

The countdown on the display shows the value of the pre-set waiting time. To activate the Interlock function, with the door in its UP limit position, hold the STOP button or the emergency stop button for more than 5 seconds.

To deactivate the interlock mode press CLOSE button. In case you want to disable the interlock function, choose the value 00 in parameter 36.

**ATTENTION! Parameter 36 is visible and selectable only if the automatic closing has been selected in parameter 32.**

To enable the Interlock function:

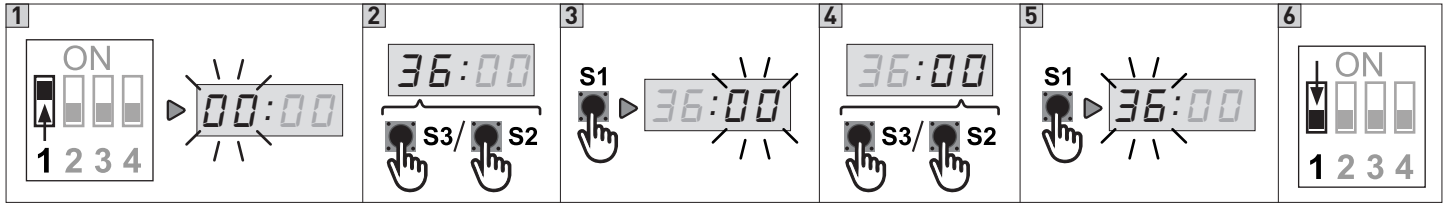

1. Put DIP 1 (S4) in ON position, PARAMETER digits start blinking
2. Using the buttons OPEN (S2) and CLOSE (S3) select the PARAMETER 36
3. Access the field VALUE pressing STOP (S1). The VALUE digits start blinking
4. Using the buttons OPEN (S2) and CLOSE (S3) vary the value
  - Value 00: interlock function OFF;
  - Value 01: interlock function ON;
5. Press the STOP button (S1) to confirm the tuning and return to the PARAMETER field.
6. **To leave the set-up mode, place the DIP1 in OFF.**

## 16\_ INTERMEDIATE POSITION (PARAMETER 16)

It is possible to set an intermediate position of the door through the parameter 16.

The factory pre-set value is 00, which excludes this function.

The use differs according to the type of limit switch: mechanical or with encoder.

### 16.1\_ INTERMEDIATE POSITION WITH MECHANICAL LIMIT SWITCHES

With mechanical limit switches, the position is determined by an auxiliary microswitch in the motor's limit switch assembly (one of the two yellow cams), which must be connected to terminals 15 and 16 of connector X3.

In this case PARAMETER 16 must have value 01.

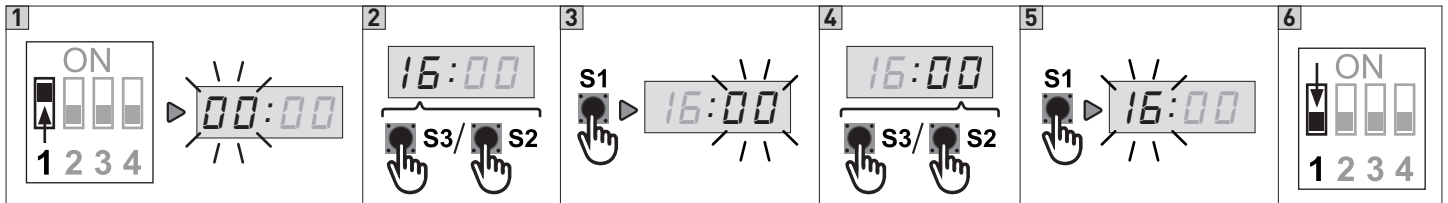

1. Put DIP 1 (S4) in ON position, PARAMETER digits start blinking
2. Using the buttons OPEN (S2) and CLOSE (S3) select the PARAMETER 16
3. Access the field VALUE pressing STOP (S1). The VALUE digits start blinking
4. Using the buttons OPEN (S2) and CLOSE (S3) vary the value
  - Value 00: Intermediate position disabled
  - Value 01: Position determined by the auxiliary microswitch
5. Press the STOP button (S1) to confirm the tuning and return to the PARAMETER field.
6. **To leave the set-up mode, place the DIP1 in OFF.**

## 16.2\_ INTERMEDIATE POSITION WITH ENCODER LIMIT SWITCHES TYPE

With encoder limit switches type the intermediate position can occur through the use of a selector or of an additional button.  
**In this case the PARAMETER 16 must be selected at Value 00.**

**If you are using a selector, this one must be connected to terminals 15 and 16 of X3.**

If you open the contact of the selector, the use of the intermediate position is inhibited.

If you close the contact of the selector, pressing the UP button, the door stops at the intermediate position.

The intermediate position can be adjusted by setting the PARAMETER 16 at values from 02 to 07 with a progressive change of the intermediate position from 50% to 75% of the travel.

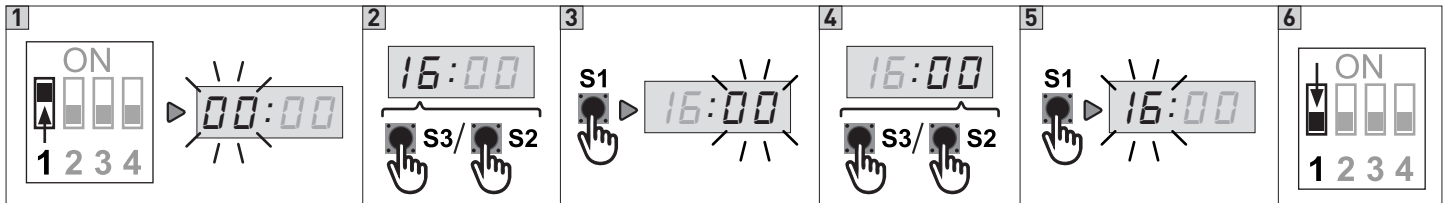

1. Put DIP 1 (S4) in ON position, PARAMETER digits start blinking
2. Using the buttons OPEN (S2) and CLOSE (S3) select the PARAMETER 16
3. Access the field VALUE pressing STOP (S1). The VALUE digits start blinking
4. Using the buttons OPEN (S2) and CLOSE (S3) vary the value
  - Value 02: Intermediate position at 50% of the travel
  - Value 03: Intermediate position at 55% of the travel
  - Value 04: Intermediate position at 60% of the travel
  - Value 05: Intermediate position at 65% of the travel
  - Value 06: Intermediate position at 70% of the travel
  - Value 07: Intermediate position at 75% of the travel

**5. To leave the set-up mode, place the DIP1 in OFF.**

**If you are using an additional button, this one must be connected to terminals 15 and 16 of X3.**

In this case the UP button allows the opening of the door up to the UP limit position.

While, to move the door to the intermediate position you have to press the additional button.

The intermediate position can be determined by setting the PARAMETER 16 with values from 08 to 13 with a progressive change of the intermediate position from 50% to 75% of the travel:

- Value 08: Intermediate position at 50% of the travel
- Value 09: Intermediate position at 55% of the travel
- VALUE 10: Intermediate position at 60% of the travel
- VALUE 11: Intermediate position at 65% of the travel
- VALUE 12: Intermediate position at 70% of the travel
- VALUE 13: Intermediate position at 75% of the travel

## 16.3\_ AUTOMATIC CLOSING FROM INTERMEDIATE POSITION (PARAMETER 17)

You can set the automatic closing even from the intermediate position setting the PARAMETER 17.

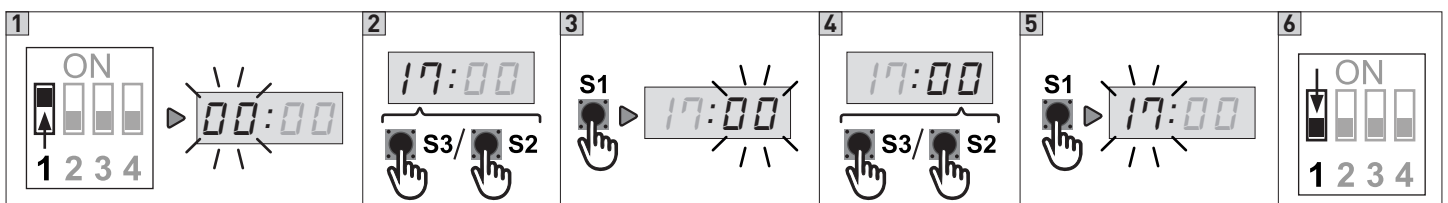

**Activate the automatic closing function (paragraph 12)**

1. Put DIP 1 (S4) in ON position, PARAMETER digits start blinking
2. Using the buttons OPEN (S2) and CLOSE (S3) select the PARAMETER 17
3. Access the field VALUE pressing STOP (S1). The VALUE digits start blinking
4. Using the buttons OPEN (S2) and CLOSE (S3) vary the value
  - Value 00: Automatic closing (from intermediate position) OFF
  - Value 01: Automatic closing (from intermediate position) ON
5. Press the STOP button (S1) to confirm the tuning and return to the PARAMETER field.
- 6. To leave the set-up mode, place the DIP1 in OFF.**

## 17\_ SAFETY DEVICES

### 17.1\_ SAFETY BEAMS (PARAMETER 31)

Refer to the safety beams instructions for the DC supply.

A 24V DC supply for the safety beams is available:

- Terminal 20 of X3 for the positive
- Terminal 19 of X3 for the mass.

**ATTENTION! Both the transmitter and the receiver of the safety beams must be connected to the same terminals.**

**Caution: Do not connect the power supply at the 24V terminal 18 instead of at the terminal 20 of the X3 dedicated to safety beams, otherwise the safety beams test cycle will fail showing on the display the error code `E:05` and preventing the control unit working. In case of an incorrect connection, restore the correct connections and press stop to start a new test cycle.**

As for the signals, the wires (normally closed) of the receiver must be connected to the terminals 21 and 22 of X3.

Through parameter 31 you can conform the control unit to the type of connection that you are going to select, in order to activate the corresponding test functions.

This test allows the control unit to constantly check of short circuits or malfunctions that could compromise the safety of the device. The test thus allows to ensure the safety even in case of single failure as required by the standards EN13241-1 and EN-12453.

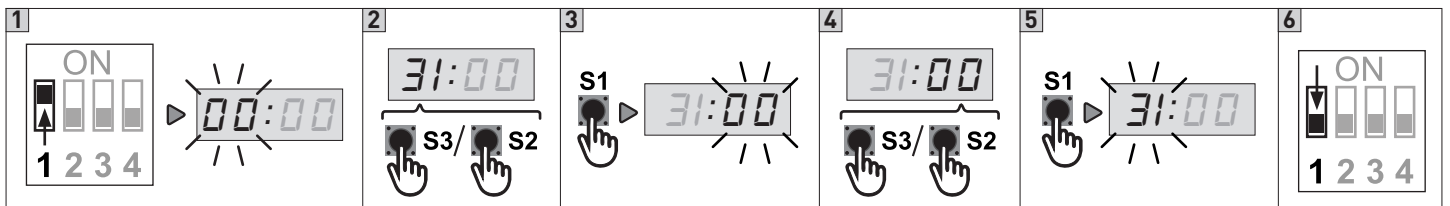

1. Put DIP 1 (S4) in ON position, PARAMETER digits start blinking
2. Using the buttons OPEN (S2) and CLOSE (S3) select the PARAMETER 31
3. Access the field VALUE pressing STOP (S1). The VALUE digits start blinking
4. Using the buttons OPEN (S2) and CLOSE (S3) vary the value
  - Value 00: No safety beams connected
  - Value 01: Connection PHOTO 1 on X12
  - Value 02: Connection PHOTO 2 on X3
  - Value 03: Connection PHOTO 1 and 2
5. Press the STOP button (S1) to confirm the tuning and return to the PARAMETER field.
6. To leave the set-up mode, place the DIP1 in OFF.

#### 17.1.1\_ ADDITIONAL PHOTO MOUNTED IN THE DOOR FRAME (ONLY POSSIBLE WITH ELECTRONIC LIMITS).

After selecting the right parameter value run mode is available by pressing stop. Location of photo will now be learned by running from close to open position. The door will stop when the photo is no longer blocked and the control unit will change back to parameter number automatically

Using the buttons OPEN (S2) and CLOSE (S3) vary the value:

- Value 04: Photo 1 connected and mounted in the door frame
- Value 05: Photo 2 connected and mounted in the door frame
- Value 06: Photo 1 and 2 connected and photo 1 mounted in the door frame
- Value 07: Photo 1 and 2 connected and photo 2 mounted in the door frame

Install additional safety photo cells in the door track to protect the photo cells from the sun and knocks. After the installation the photo cells will automatically be disabled when the door passes the photo beam.

**Avoid mounting the photo receiver on the door side where the sun is shining directly on the sensor when the sun is low!**

## 17.1.2\_ REVERSE TIME - Photo (PARAMETER 53)

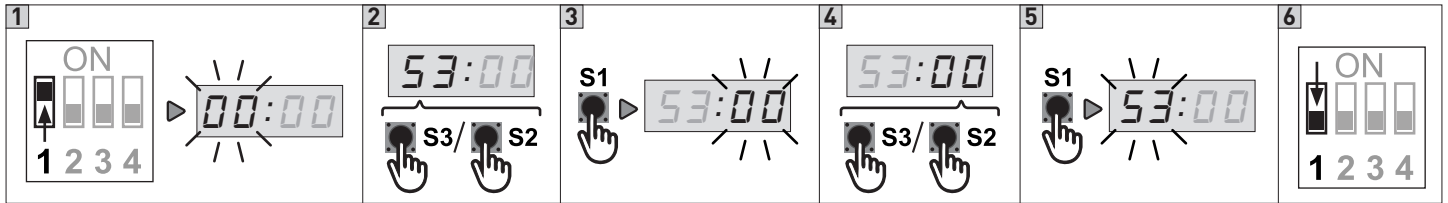

1. Put DIP 1 (S4) in ON position, PARAMETER digits start blinking
2. Using the buttons OPEN (S2) and CLOSE (S3) select the PARAMETER 53
3. Access the field VALUE pressing STOP (S1). The VALUE digits start blinking
4. Using the buttons OPEN (S2) and CLOSE (S3) vary the value
  - Value ...: Reverse time of Photo in 1/100 seconds. 0.05 – 0.99 sec. Example: 30 = 0.30 sec.
  - This reverse time is also used as force reversing time.
5. Press the STOP button (S1) to confirm the tuning and return to the PARAMETER field.
6. **To leave the set-up mode, place the DIP1 in OFF.**

## 17.2\_ SAFETY EDGE (PARAMETER 21)

Safety edge connection: in case of resistive safety edges type 8k2 ohm or pneumatic safety edges, connect the wires to the terminals 23 and 24 of X3;

In case of optoelectronic safety edge, connect the wires to the terminals 25, 26 and 27 of X3 [respecting the color order].

### Warning:

- if you choose the optical safety edge (VALUE 03) the terminals 23 and 24 DO NOT have to be connected by a jumper.
- if you DO NOT want to use a safety edge, select the VALUE 01 and connect the terminals 23 and 24 with a jumper. The terminals 25, 26 and 27 of X3 must not be connected.
- the safety edge must be connected before the selection of PARAMETER 21, but do not activated them. If this happens, the control unit shows an error signal on the display the code **ERR**. The same happens if you choose a parameter that does not match with the connected terminals.

Through PARAMETER 21 you can select the type of safety edge.

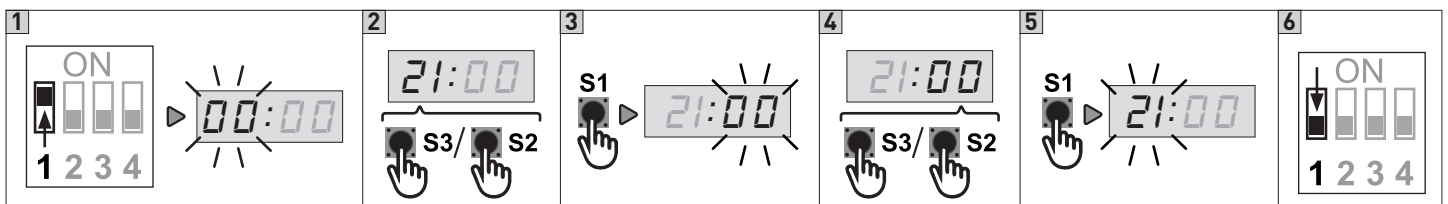

1. Put DIP 1 (S4) in ON position, PARAMETER digits start blinking
2. Using the buttons OPEN (S2) and CLOSE (S3) select the PARAMETER 21
3. Access the field VALUE pressing STOP (S1). The VALUE digits start blinking
4. Using the buttons OPEN (S2) and CLOSE (S3) vary the value
  - Value 01: PNE / DW pneumatic
  - Value 02: Safety edge with resistive contact 8k2 ohm
  - Value 03: Optoelectronic edge
  - Value 04: Special LP / DW pneumatic
  - Value 05: Wireless edge with test function on X20 s.out
  - Value 06: Light curtain with OSE output
5. Press the STOP button (S1) to confirm the tuning and return to the PARAMETER field.
6. **To leave the set-up mode, place the DIP1 in OFF.**

### Note:

- that actual edge must be connected but not activated before this setup. If the controller has observed a wrong edge select, the display will show **ERR**.
- that nothing must be connected to X3 terminal 23-24 when parameter value 03 or 06 has been chosen.

## 17.3\_ EXTRA SAFETY EDGE OR WICKET DOOR/SLACK ROPE CIRCUIT (PARAMETER 23)

Connection of the secondary safety contact strip: in the case of a resistive 8k2 ohm or pneumatic type contact strip, connect the conductors of the contact strip to terminals 3 and 4 of connector X20;

**Caution: the moving rib must be connected before PARAMETER 23 is selected. If this happens, the control unit returns an error signal by showing the code `ERR` on the display. The same happens if a parameter is selected which does not correspond to the connected terminals.**

By means of PARAMETER 23, it is possible to determine the type of secondary moving rib used on the door.

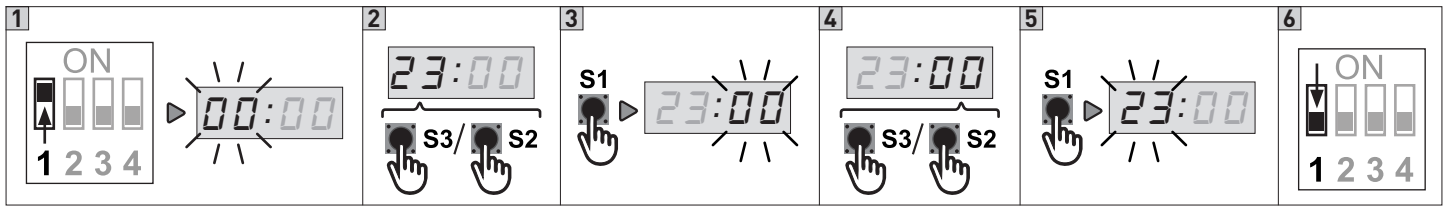

1. Put DIP 1 (S4) in ON position, PARAMETER digits start blinking
2. Using the buttons OPEN (S2) and CLOSE (S3) select the PARAMETER 23
3. Access the field VALUE pressing STOP (S1). The VALUE digits start blinking
4. Using the buttons OPEN (S2) and CLOSE (S3) vary the value
  - Value 00: No extra safety edge list
  - Value 01: Extra safety edge list works parallel with primary safety edge list\*\*
  - Value 02: Extra safety list stops door in opening direction\*
  - Value 03: Extra safety list stops door and reverse a little in opening direction\*
5. Press the STOP button (S1) to confirm the tuning and return to the PARAMETER field.
6. To leave the set-up mode, place the DIP1 in OFF.

\* Extra safety list shall be PNE/air switch or 8k2 type and the same type as primary safety edge list  
If parameter 88:03 (lock function), it is not possible to mount extra safety edge.

\*\* For the anti-shear function, connect a photocell instead of the moving rib.

### 17.3.1\_ REVERSE TIME - Safety edge (PARAMETER 52)

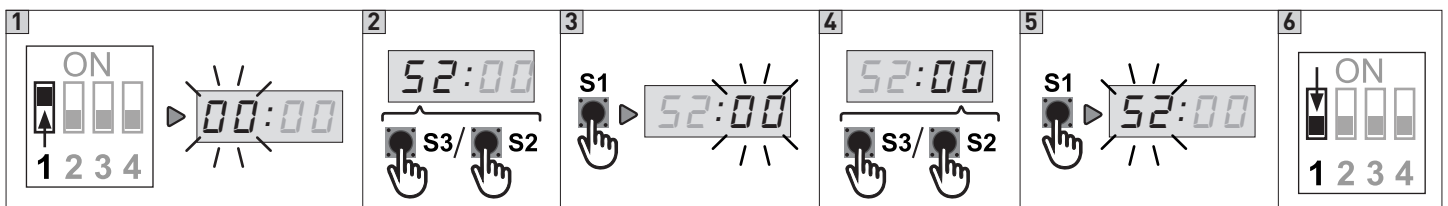

1. Put DIP 1 (S4) in ON position, PARAMETER digits start blinking
2. Using the buttons OPEN (S2) and CLOSE (S3) select the PARAMETER 52
3. Access the field VALUE pressing STOP (S1). The VALUE digits start blinking
4. Using the buttons OPEN (S2) and CLOSE (S3) vary the value
  - Value 00: reverse time is set to minimum 0.004 sec
  - Reverse time of safety edge in 1/100 seconds. 0.00 – 0.99 sec. Example: 01 = 0.01 sec.
5. Press the STOP button (S1) to confirm the tuning and return to the PARAMETER field.
6. To leave the set-up mode, place the DIP1 in OFF.

## 18\_ REACTION – FAILURE ON PHOTO OR SAFETY EDGE LIST (PARAMETER 02)

By means of PARAMETER 02, it is possible to determine the behaviour of the damper as a result of an error in the photocell or moving rib.

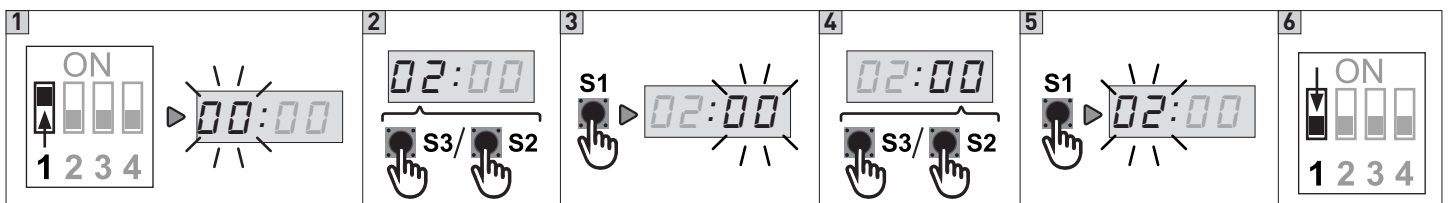

1. Put DIP 1 (S4) in ON position, PARAMETER digits start blinking
2. Using the buttons OPEN (S2) and CLOSE (S3) select the PARAMETER 02
3. Access the field VALUE pressing STOP (S1). The VALUE digits start blinking

4. Using the buttons OPEN (S2) and CLOSE (S3) vary the value
  - Value 00: Hold to run operation not possible when failure on photo or safety edge list.
  - NOTE.** The door cannot close when there is an error on photo or safety edge. By a special code the door can close one time in hold to run mode. Press and hold STOP when pressing 222111 (2 = DOWN push button and 1 = UP push button).
  - Value 01: Hold to run possible when failure on photo or safety edge list.
  - ATTENTION: DO NOT USE 01 WHEN A DEVICE WITH CONSTANT CLOSE SIGNAL IS MOUNTED.**
  - USAGE OF 01 IS ON CUSTOMERS OWN RISK.**
5. Press the STOP button (S1) to confirm the tuning and return to the PARAMETER field.
6. **To leave the set-up mode, place the DIP1 in OFF.**

## 19\_ AUX (relè K3 - Max 230Vac/5A) (PARAMETER 88)

Through PARAMETER 88 it is possible to determine the behavior of relé K3.



1. Put DIP 1 (S4) in ON position, PARAMETER digits start blinking
  2. Using the buttons OPEN (S2) and CLOSE (S3) select the PARAMETER 88
  3. Access the field VALUE pressing STOP (S1). The VALUE digits start blinking
- Using the buttons OPEN (S2) and CLOSE (S3) vary the value
- Value 00: active relé while the door is moving
  - Value 01: active relé while the door is in the DOWN limit switch position
  - Value 02: active relé while the door is in the UP limit switch position
  - Value 03: the relé is used for the electric closure: it activates for one second during the opening and ONLY if the door is closed
4. Press the STOP button (S1) to confirm the tuning and return to the PARAMETER field.
  5. **To leave the set-up mode, place the DIP1 in OFF.**

## 20\_ ADDITIONAL RADIO RECEIVER SLOT QCMR500 (OPTIONAL) - “GO FUNTION”

**WARNING:** The QCMR500 in conjunction with the QC500 inhibits the use of the second photocell on terminal block X12 input PHOTO1

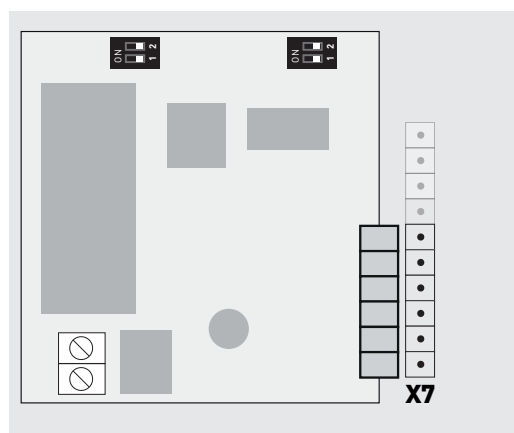

The control unit can be radio operated thanks to the QCTE transmitter that allows the storage of 1997 radio codes. The QCTE transmitter must be matched to the QCMR500 radio receiver slot, already connected to slot X7 (see page 6).

**Please look at the instructions attached to the QCMR500 slot in order to connect it to the control unit and to match it to the transmitter.**

**NOTE: Set working mode: 01:03** Impulsive OPEN; Impulsive CLOSE. **REQUIRED WITH RADIO MODULE QCMR500-OPTIONAL.**



Once the QCMR500 slot is inserted, you can set up its operation mode through PARAMETER 35 (parameter 35 is visible ONLY if the photocell is active through parameter 31):

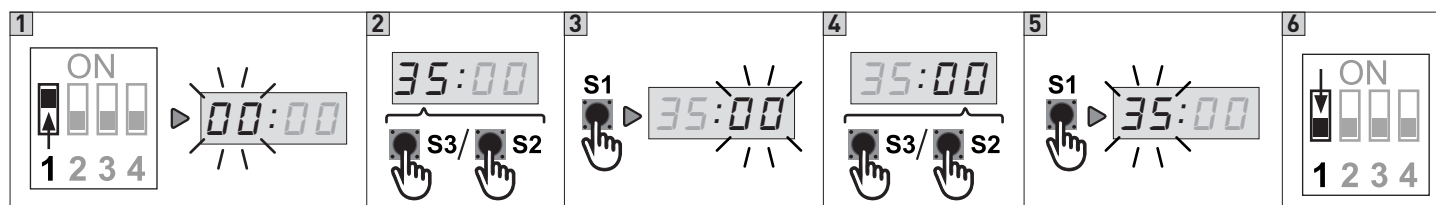

1. Put DIP 1 (S4) in ON position, PARAMETER digits start blinking
2. Using the buttons OPEN (S2) and CLOSE (S3) select the PARAMETER 35
3. Access the field VALUE pressing STOP (S1). The VALUE digits start blinking
4. Using the buttons OPEN (S2) and CLOSE (S3) vary the value

- Value 00: **GENERAL MODE OF OPERATION**

the signal of the transmitter always commands the opening, except when the door is already completely opened. In this case it commands the closure.

- Value 01: **GENERAL MODE OF OPERATION + STOP**

the signal stops the movement of the door **ONLY** while opening

- Value 02: **MODE OF OPERATION "ONLY OPENING"**

the signal of the transmitter only activates the opening of the door. If the door is closing, the signal changes the movement till the UP limit switch position has been reached.

- Value 03: **MODE OF OPERATION "STEP BY STEP"**

every time the signal of the transmitter is activated, it accomplishes the following commands:

OPEN > STOP > CLOSE > STOP sequentially.

**NOTE: if the AUTOMATIC CLOSURE has been programmed, during the pause the signal of the transmitter will extend the pause by resetting the timer of the automatic closure.**

5. Press the STOP button (S1) to confirm the tuning and return to the PARAMETER field.

6. To leave the set-up mode, place the DIP1 in OFF.

**NOTE :** the entrance "GO" (terminals 9-10 on X1) follows the same logical of functioning selected for radio receiver (parameter 35).

## 21\_ AFTER RUN (PARAMETER 22)

Used to prevent that the door reverses when it reaches the floor before the close limit gets activated – for instance if there is dirt in the door opening or if the wires are getting longer

**Monitoring of the PNE/DW air switch safety edge is only active when after run is selected parameter 22:01-50**



1. Put DIP 1 (S4) in ON position, PARAMETER digits start blinking
2. Using the buttons OPEN (S2) and CLOSE (S3) select the PARAMETER 22
3. Access the field VALUE pressing STOP (S1). The VALUE digits start blinking
4. Using the buttons OPEN (S2) and CLOSE (S3) vary the value

- Value 00: No after run (Note! Value 00 = NO monitoring of PNE/DW)\*

- Value > 00: After run active – after run time 0.01 – 0.50 sec.

5. Press the STOP button (S1) to confirm the tuning and return to the PARAMETER field.

6. To leave the set-up mode, place the DIP1 in OFF.

**\* Monitoring of the PNE/DW air switch safety edge is only active when after run is selected parameter 22:01-50**

### PROGRAMMING:

Set close limit switch about 1-3 cm over the floor. Adjust the door to the floor by setting the after run time on the right level until the door stops on PNE/DW signal from the safety list.

## 22\_ WIRE TIGHTEN (PARAMETER 29)

Used to prevent the wire is getting loose when the door is closed. Works as a small pull back time when the door stops on close limit

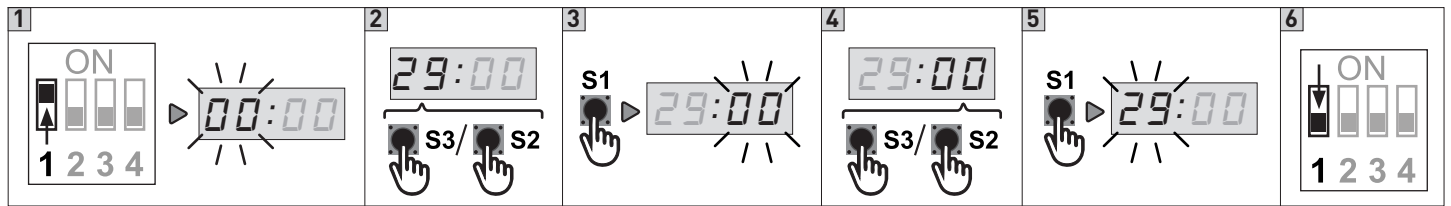

1. Put DIP 1 (S4) in ON position, PARAMETER digits start blinking
2. Using the buttons OPEN (S2) and CLOSE (S3) select the PARAMETER 29
3. Access the field VALUE pressing STOP (S1). The VALUE digits start blinking
4. Using the buttons OPEN (S2) and CLOSE (S3) vary the value
  - Value 00: No wire tighten function
  - Value 01: Wire tighten 5 mS
  - Value 02: Wire tighten 10 mS
  - Value 03: Wire tighten 20 mS
  - Value 04: Wire tighten 30 mS
5. Press the STOP button (S1) to confirm the tuning and return to the PARAMETER field.
6. To leave the set-up mode, place the DIP1 in OFF.

## 23\_ SERVICE COUNTER (PARAMETER 58)

Use service counter to make service interval on doors.

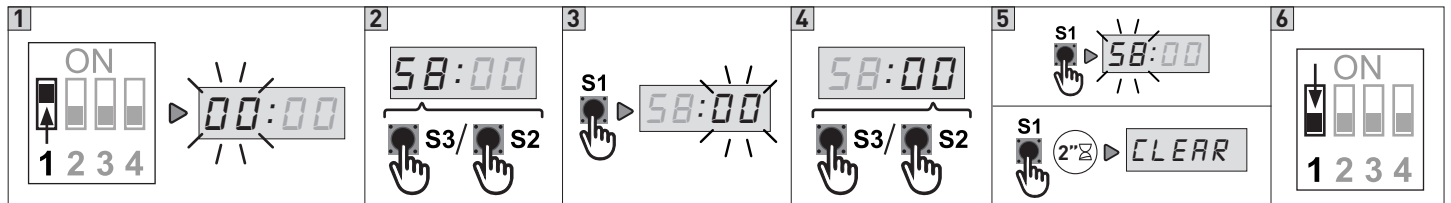

1. Put DIP 1 (S4) in ON position, PARAMETER digits start blinking
2. Using the buttons OPEN (S2) and CLOSE (S3) select the PARAMETER 58
3. Access the field VALUE pressing STOP (S1). The VALUE digits start blinking
4. Using the buttons OPEN (S2) and CLOSE (S3) vary the value
  - Value 00: No Service countdown
  - Value 01: 15 open cycles before service **(for test only)**
  - Value 02: 5000 open cycles before service
  - Value 03: 10000 open cycles before service
  - Value 04: 20000 open cycles before service
5. Press the STOP button (S1) once again to confirm the tuning and return to the PARAMETER field.  
**NOTE: Press STOP again minimum 2 sec CLEAR is shown 2 sec. in display to confirm new countdown**
6. To leave the set-up mode, place the DIP1 in OFF.

### 23.1\_ Service count reaction (PARAMETER 59)

Use to choose the default action when the chosen number of cycles is reached.

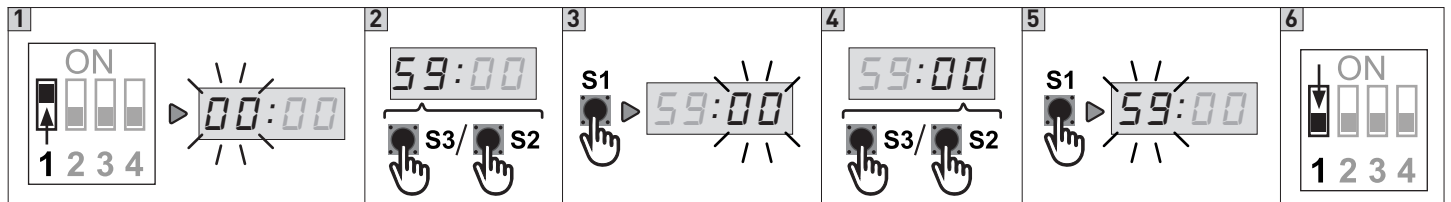

1. Put DIP 1 (S4) in ON position, PARAMETER digits start blinking
2. Using the buttons OPEN (S2) and CLOSE (S3) select the PARAMETER 59
3. Access the field VALUE pressing STOP (S1). The VALUE digits start blinking
4. Using the buttons OPEN (S2) and CLOSE (S3) vary the value
  - Value 00: Display shows **E:04**
  - Value 01: Switch to hold-to-run control and display shows **E:04**
5. Press the STOP button (S1) to confirm the tuning and return to the PARAMETER field.
6. To leave the set-up mode, place the DIP1 in OFF.

## 24\_ SPECIAL OPEN OR CLOSE FUNCTION (PARAMETER 84)

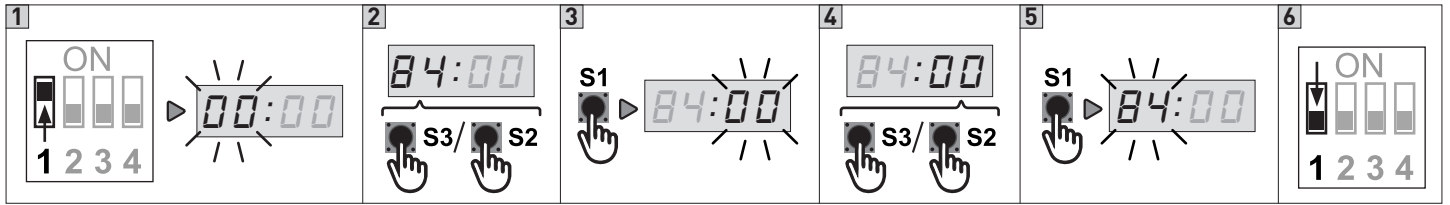

1. Put DIP 1 (S4) in ON position, PARAMETER digits start blinking
2. Using the buttons OPEN (S2) and CLOSE (S3) select the PARAMETER 84
3. Access the field VALUE pressing STOP (S1). The VALUE digits start blinking
4. Using the buttons OPEN (S2) and CLOSE (S3) vary the value
  - Value 00: Normal open function.
  - Value 01: Special open function: Open signal with high priority.  
**The door will always open on a continuously open signal, even after a stop impulse. (E.g. a fire open signal)**
  - Value 02: Special close function: Close signal with high priority.  
**The door will always close on a continuously close signal, even after a stop impulse. (E.g. a fire close signal)**
5. Press the STOP button (S1) to confirm the tuning and return to the PARAMETER field.
6. To leave the set-up mode, place the DIP1 in OFF.

## 25\_ FLASHING LIGHT CONNECTION (230Vac with autolamping) / COURTESY LAMP

**Warning: Invalid connection in the 3~230V connection configuration.**

In this case, use the additional QCLSM module to connect to X8 (see fig. 2).

**Note: For correct use of the QCLSM module, refer to the relevant instruction manual.**

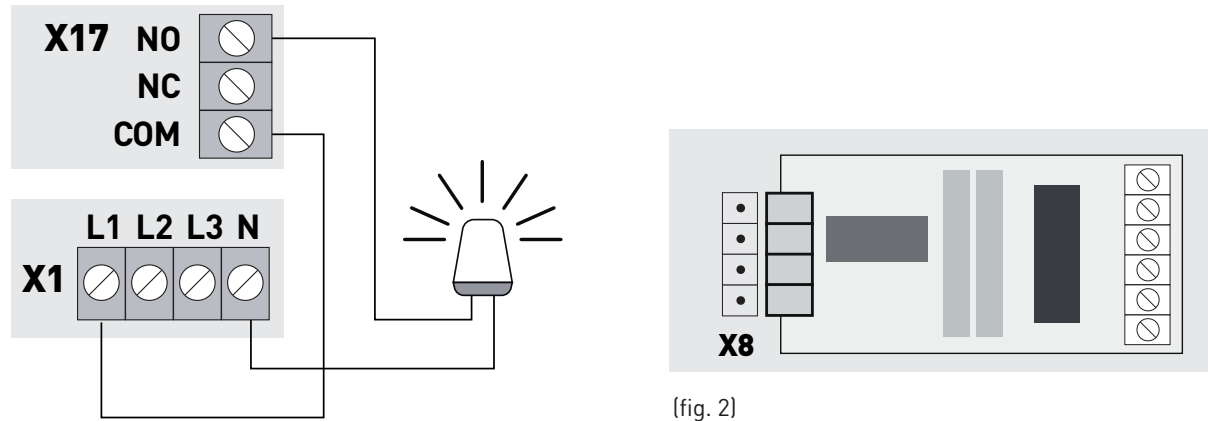

## 26\_ QCLSM RELAY MODULE SETTINGS (OPTIONAL) (PARAMETER 75)

Function setup for the Relay module is made in parameter 75 and 76.

Parameter 75 is for AUX4 and parameter 76 is for AUX5.

The function modes are similar for parameter 75 and 76, (75 is shown below):

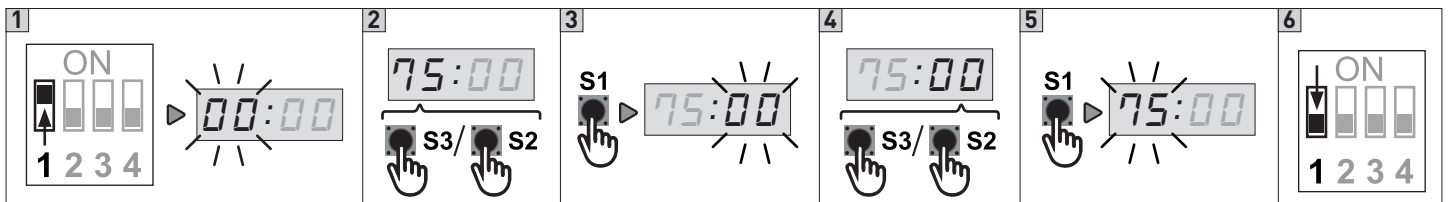

1. Put DIP 1 (S4) in ON position, PARAMETER digits start blinking
2. Using the buttons OPEN (S2) and CLOSE (S3) select the PARAMETER 75
3. Access the field VALUE pressing STOP (S1). The VALUE digits start blinking
4. Using the buttons OPEN (S2) and CLOSE (S3) vary the value



75:00	No functions.	75:17	ON when safety edge is activated or safety test error on the safety edge.
75:01	Flashing function by warning and ON when door is running.	75:18	Flashing by warning and OFF by door running.
75:02	Flashing function by warning and running.	75:19	ON just before and by open limit position. Setpoint by parameter 91 (electronic limits only)
75:03	ON by warning and running.	75:23	ON by OPEN limit position
75:04	1 sec. impulse ON by OPEN command.	75:24	ON for 1 sec. impulse by every motor start.
75:05	ON by Error (LED D15).	75:25	ON by opening and 2 minutes after stopped on OPEN limit.
75:06	ON by OPEN limit position.	75:26	Alternative output signal for wireless safety edge. (parameter 21:05)
75:07	ON by CLOSE limit position.	75:27	ON impulse for 2 sec. when OPEN limit is reached
75:08	OFF by OPEN limit position, all other situations ON	75:28	Relay OFF.
75:09	OFF by CLOSE limit position, all other situations ON	75:29	ON when door opening
75:12	ON just before and by closed limit position. Setpoint by parameter 92 (electronic limits only)	75:30	ON when door closing
75:13	ON by running + 0.4 sec. delay added before and after running	75:31	ON when service interval is reached (parameter 58)
75:14	ON when motor is running (e.g. brake relay)	75:35	ON by Photocell signal OK. Off by interrupted photo beam
75:15	ON when motor is not running.	75:43	ON when door is running up or down
75:16	ON when motor is running and on open limit.		

#### PARAMETERS ONLY IN USE WHEN WARNING ARE SELECTED IN PARAMETER 75 OR 76

77:00	Time setup start delay (adjustable 1-10 sec.), both directions, relay warning in close direction	78:00	Time setup warning close direction (adjustable 0-120 sec. – above 100 in 10sec. steps)
-------	--	-------	--

### 26.1\_ Set point Open (Relay module) (PARAMETER 91)

Set point for Relay module parameter 75/76:19



- Put DIP 1 (S4) in ON position, PARAMETER digits start blinking
- Using the buttons OPEN (S2) and CLOSE (S3) select the PARAMETER 91
- Access the field VALUE pressing STOP (S1). The VALUE digits start blinking
- Using the buttons OPEN (S2) and CLOSE (S3) vary the value
  - Value 00: 5 % before open limit
  - Value 01: 10 % before open limit
  - Value 02: 15 % before open limit
  - Value 03: 20 % before open limit
  - Value 04: 25 % before open limit
  - Value 05: 30 % before open limit
  - Value 06: 35 % before open limit
  - Value 07: 40 % before open limit
- Press the STOP button (S1) to confirm the tuning and return to the PARAMETER field.
- To leave the set-up mode, place the DIP1 in OFF.**

## 26.2\_ Set point Close (Relay module) (PARAMETER 92)

Set point for Relay module parameter 75/76:12

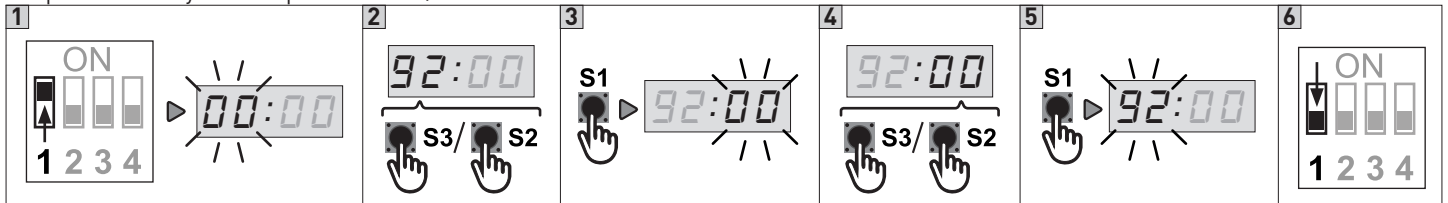

1. Put DIP 1 (S4) in ON position, PARAMETER digits start blinking
2. Using the buttons OPEN (S2) and CLOSE (S3) select the PARAMETER 92
3. Access the field VALUE pressing STOP (S1). The VALUE digits start blinking
4. Using the buttons OPEN (S2) and CLOSE (S3) vary the value
  - Value 00: 5 % before closed limit
  - Value 01: 10 % before closed limit
  - Value 02: 15 % before closed limit
  - Value 03: 20 % before closed limit
  - Value 04: 25 % before closed limit
  - Value 05: 30 % before closed limit
  - Value 06: 35 % before closed limit
  - Value 07: 40 % before closed limit
5. Press the STOP button (S1) to confirm the tuning and return to the PARAMETER field.
6. **To leave the set-up mode, place the DIP1 in OFF.**

## 27\_ ELECTRONIC COUNTER AND LAST 10 ERRORS

Use to view the error history counter.

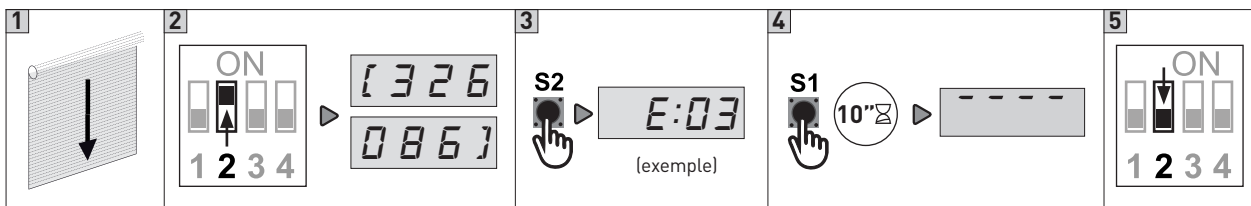

1. Close the door **(The door cannot be moved when display status is active)**
2. Put DIP 2 (S4) in ON position.  
The display is flashing between and the most significant digits.  
Example shown is [326] and [086] = 362086 door openings
3. Press OPEN (S2) to select newer error (p.e. [E:03]).  
Press CLOSE (S3) to select older error.  
If there is no errors the display will show: [----]  
By the end of the registered 10 errors the display will show:  
Upper end [----] / lower end [----]
4. Reset of last 10 errors by pressing OPEN at least 10 sec. when [----] symbol is shown
5. **To leave the set-up mode, place the DIP2 in OFF.**

## 28\_ TROUBLESHOOTING

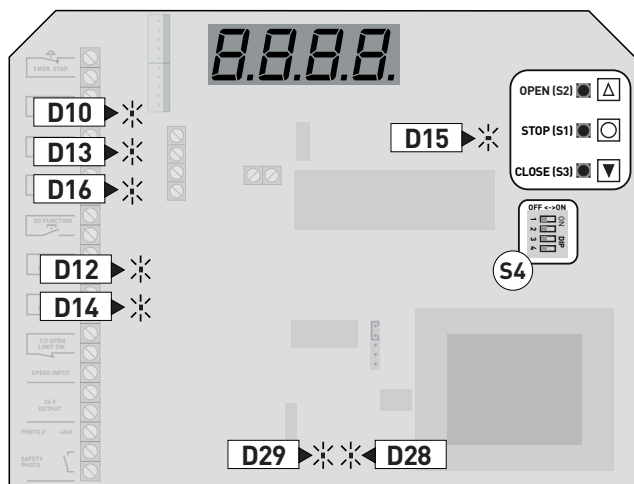

LED:

**D15** - Error diode - Flashing 1-9 times  
**D10** - STOP active  
 ( X3:1-2, X3:3-4, X3:28-29, X13:2-5, X2:4-5 )  
 LED is also active in fail mode. Observe display and  
 D15 ERROR LED





















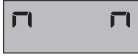

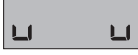
**D13** - Open Limit  
**D16** - Close Limit  
**D12** - Close Limit active  
**D14** - Open Limit active  
**D28** - Power ON to Open contactor  
**D29** - Power ON to Close contactor

## 29\_ ERROR CODES - D15 ERROR LED (used when electronic limits is selected)

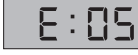
FLASHES ON D15 ERROR LED	ERROR EXPLANATION	SOLVING ERROR
1	No answer from encoder (No 24Vdc control voltage)	- Check connections - Check the 24VDC voltage in terminal 18-19 of X3
2	Limits not learned	Learn limits
3	Motor running unintended	Service needed. Fatal error. Move the door manual to middle position without power. Change from normal mode to programming mode on DIP switch no. 1. This will clear the SER error. If the door is running again in 1 sec. without command when power is on then the PCB is defect.
4	Calculation error	Check that parameter 11 value is correct selected. (Left/right turning select). Possible user error – both limits are the same. Encoder error.
5	Not in use	
6	Not in use	
7	Encoder: position out of learned range.	Re-learn limits
	encoder – wrong selection of left/right turning	Check that parameter 11 value is correct selected. (Left/right turning select) or re-learn limits
8	Encoder – Failure operating voltage	Check connection and supply voltage. Change encoder
9	EEPROM failure on IC4 by power up	- Re-learn limits and make a new power-up. (In that order!) Or - Make a factory resetting and a new power-up. (In that order!)

## 30\_ DISPLAY IN RUN MODE

The display will in run mode show status of limits, some inputs or error codes if they occurs.  
When power up the software version is showed shortly.

	<ul style="list-style-type: none"> <li>Nothing active. (4 chairs symbol)</li> <li>Door is stopped between limits and no errors are found.</li> </ul>		<b>GO function active</b> (Note that the door only can be closed by GO function, when photo is installed)
	<b>Open limit active</b>		<b>Photo 1 active</b> Photo 2 is external photo cells mounted in the screw terminals X12.
	<b>Close limit active</b>		<b>Photo 2 active</b> Photo 2 is external photo cells mounted in the screw terminals X3.
	<b>1/2 open limit active</b>		<b>Safety Edge active</b>
	<b>Stop active</b>		<b>Safety list not mounted correct / wrong selection in parameter 21.</b>
	<b>OPEN push-button active</b>		<b>Door running up</b>
	<b>CLOSE push-button active</b>		<b>Door running down</b>
	<b>Error code. Door is running without command</b> Service needed. Fatal error. Move the door manual to middle position without power. Change from normal mode to programming mode on DIP switch no. 1. This will clear the SER error. If the door is running again in 1 sec. without command when power is on then the PCB is defect.		
	<b>Error code. Edge monitoring</b> Error code Monitoring failure of safety edge if this function is activated. Check or adjust safety edge list. See chapter 1.5.		<b>Error code. Run time</b> Error code. Door is stopped on run time control.
	<b>Error code. Service</b> Service counter decremented to 0 Reset for new countdown		<b>Error code. Photo</b> Failure in photo circuit. (Test cycle after last stop failed, Press stop to start new test)
	<b>Error code. Safety Edge</b> Failure in edge circuit. (Test cycle after last stop failed, Press stop to start new test)		
	<b>Error code. no change of encoder position, when running.</b> Door started, but the position is not changing. Door is stopped after delay time and E:09 failure is shown about 1 sec. Possible errors: The door is blocked, disengaged, cable connection error or the encoder magnet is not fixed on the shaft. Reset of E09: both limits shall be founded again by hold-to-run steps. (If it is not possible to find both limits, the limits must be relearned) If necessary, adjust in parameter 81 (delay time) (Parameter 81:03 = autoreset)		
	<b>Error code. EEPROM Fail</b> Possible error: Limits has been changed, after the force control has been learned. Reset of E20: Try deactivating force control in parameter 41 ( 41:00 ) and after this make a new power-up.		<b>Error code. EEPROM Fail</b> EEPROM failure of power-up. Try factory clear or change processor.
	<b>Error on 24V and/or 12V voltage circuit.</b> 24/12V is shorted or overloaded.		
			

## 31\_ PARAMETER LIST

<b>01:00</b>	<b>OPERATION MODE</b>
01:01	Hold-to-run OPEN - Hold-to-run CLOSE
01:02	Impulse OPEN - Hold-to-run CLOSE
01:03	Impulse OPEN - Impulse CLOSE
01:04	No active
<b>02:00</b>	<b>REACTION – FAILURE ON PHOTO OR SAFETY EDGE LIST</b>
02:00	Hold to run operation not possible when failure on photo or safety edge list
02:01	Hold to run possible when failure on photo or safety edge list
<b>11:00</b>	<b>SELECTION OF LIMITS</b>
11:00	Mechanical limits
11:01	Encoder limit right turning
11:02	Encoder limit left turning
11:03	Not in use
11:04	Not in use
11:05	Encoder - right turning
11:06	Encoder - left turning
<b>12:00</b>	<b>TUNING OF ELECTRONIC LIMIT OPEN - See instructions</b>
<b>13:00</b>	<b>FINE TUNING OF ELECTRONIC LIMIT OPEN - See instructions</b>
<b>14:00</b>	<b>TUNING OF ELECTRONIC LIMIT CLOSE -See instructions</b>
<b>15:00</b>	<b>FINE TUNING OF ELECTRONIC LIMIT CLOSE - See instructions</b>
<b>16:00</b>	<b>½ OPEN SELECT</b>
16:00	No active
16:01	½ open stop active. Position controlled by mechanical micro switch
16:02	½ open stop active. Electronic limit on 50 % open position.
16:03	½ open stop active. Electronic limit on 55 % open position.
16:04	½ open stop active. Electronic limit on 60 % open position.
16:05	½ open stop active. Electronic limit on 65 % open position.
16:06	½ open stop active. Electronic limit on 70 % open position.
16:07	½ open stop active. Electronic limit on 75 % open position
16:08	½ open stop active. Electronic limit on 50 % open position.
16:09	½ open stop active. Electronic limit on 55 % open position.
16:10	½ open stop active. Electronic limit on 60 % open position.
16:11	½ open stop active. Electronic limit on 65 % open position.
16:12	½ open stop active. Electronic limit on 70 % open position.
16:13	½ open stop active. Electronic limit on 75 % open position.

<b>17:00</b>	<b>AUTO CLOSE FROM ½ OPEN</b>
17:00	No active
17:01	Active
<b>21:00</b>	<b>SAFETY EDGE SELECTION</b>
21:01	PNE / DW air switch
21:02	8k2 ohm electrical
21:03	Optical
21:04	Special LP DW air switch
21:05	Wireless edge with test function on X20 s.out
21:06	Light curtain with OSE output
<b>22:00</b>	<b>AFTER RUN</b>
22:00	No after run
>00	After run active – after run time 0.01 – 0.50 sec.
<b>23:00</b>	<b>EXTRA SAFETY EDGE</b>
23:00	No extra safety edge list
23:01	Extra safety edge list works parallel with primary safety edge list
23:02	Extra safety list stops door in opening direction
23:03	Extra safety list stops door and reverse a little in opening direction
<b>29:00</b>	<b>WIRE TIGHTEN</b>
29:00	No wire tighten function
29:01	Wire tighten 5 mS
29:02	Wire tighten 10 mS.
29:03	Wire tighten 20 mS.
29:04	Wire tighten 30 mS.
<b>31:00</b>	<b>SAFETY BEAMS SETTINGS</b>
31:00	No Photo safety connected
31:01	Photo 1 connected
31:02	Photo 2 connected
31:03	Photo 1 and 2 connected
31:04	Photo 1 connected and mounted in the door frame
31:05	Photo 2 connected and mounted in the door frame
31:06	Photo 1 and 2 connected and photo 1 mounted in the door frame
31:07	Photo 1 and 2 connected and photo 2 mounted in the door frame
<b>32:00</b>	<b>AUTO CLOSE SELECT</b>
32:00	No auto closing
>00	Seconds 1 – 990 (after 99 the changing will be in x10 of seconds and the value is flashing quickly)



<b>33:00</b>	<b>CAR WASH FUNCTION</b>
33:00	No car wash function
>00	Photo active time in 0,1 sec. Units (e. g. 15 = 1,5 sec.) - (Adjustable 1 – 30 units – 0,1 sec. to 3,0 sec.)
<b>34:00</b>	<b>"FORCED" CLOSING</b>
34:00	No forced closing
34:01	Forced closing after 2 min. (even though photo has not been activated).
34:02	Forced closing after 5 min. (even though photo has not been activated).
34:03	Forced closing after 10 min. (even though photo has not been activated).
34:04	Forced closing after 20 min. (even though photo has not been activated).
<b>35:00</b>	<b>GO FUNCTION</b>
35:00	Normal go function (Closing is only possible from open limit)
35:01	Special go function (stop command possible in opening direction)
35:02	Go function with open function only
35:03	Special go function: open – stop – close – stop – open – etc
<b>36:00</b>	<b>INTERLOCK FUNCTION</b>
36:00	Interlock function OFF
36:01	Interlock function ON
<b>51:00</b>	<b>RUN TIME CONTROL</b>
51:00	No run time control
51:01	Run time 20 sec.
51:02	Run time 40 sec.
51:03	Automatic learning
51:04	Run time 60 sec.
<b>52:00</b>	<b>SAFETY EDGE</b>
	Reverse time of safety edge in 1/100 seconds. 0.00 – 0.99 sec. (default 0,004 sec.)
<b>53:00</b>	<b>REVERSE TIME OF PHOTO</b>
	Reverse time of Photo in 1/100 seconds. 0.05 – 0.99 sec. (default 0,30 sec.)
<b>58:00</b>	<b>SERVICE COUNTER SETUP</b>
58:00	No Service countdown
58:01	15 open cycles before service (for test only)
58:02	5000 open cycles before service
58:03	10000 open cycles before service
58:04	20000 open cycles before service
<b>59:00</b>	<b>SERVICE COUNT REACTION</b>
59:00	Display shows E:04
59:01	Switch to hold-to-run control and display shows E:04

<b>75:00</b>	<b>RELAY MODULE SETTINGS</b>
75:00	No functions.
75:01	Flashing function by warning and ON when door is running.
75:02	Flashing function by warning and running.
75:03	ON by warning and running.
75:04	1 sec. impulse ON by OPEN command.
75:05	ON by Error (LED D15).
75:06	ON by OPEN limit position.
75:07	ON by CLOSE limit position.
75:08	OFF by OPEN limit position, all other situations ON
75:09	OFF by CLOSE limit position, all other situations ON
75:12	ON just before and by closed limit position. Setpoint by parameter 92 (electronic limits only)
75:13	ON by running + 0.4 sec. delay added before and after running
75:14	ON when motor is running (e.g. brake relay)
75:15	ON when motor is not running.
75:16	ON when motor is running and on open limit.
75:17	ON when safety edge is activated or safety test error on the safety edge.
75:18	Flashing by warning and OFF by door running.
75:19	ON just before and by open limit position. Setpoint by parameter 91 (electronic limits only)
75:23	ON by OPEN limit position
75:24	ON for 1 sec. impulse by every motor start.
75:25	ON by opening and 2 minutes after stopped on OPEN limit.
75:26	Alternative output signal for wireless safety edge. (parameter 21:05)
75:27	ON impulse for 2 sec. when OPEN limit is reached
75:28	Relay OFF.
75:29	ON when door opening
75:30	ON when door closing
75:31	ON when service interval is reached (parameter 58)
75:35	ON by Photocell signal OK. Off by interrupted photo beam
75:43	ON when door is running up or down
<b>81:00</b>	<b>DELAY TIME INDICATION OF MISSING ENCODER POSITION</b>
81:00	1 second
81:01	2 second
81:02	4 second
81:03	4 second with automatic reset
<b>84:00</b>	<b>SPECIAL OPEN FUNCTION</b>
84:00	Normal open function
84:01	Special open function (Open signal with high priority. The door will always open on a continuously open signal, even after a stop command)
84:02	Special close function (Close signal with high priority. The door will always close on a continuously close signal, even after a stop command)
<b>88:00</b>	<b>OPTION RELAY</b>
88:00	Relay active when door is running
88:01	Relay active when the door is closed
88:02	Relay active when the door is open
88:03	Relay used for electric lock

---

**91:00 Set point Open (Relay module)**

**91:00** 5 % before open limit

**91:01** 10 % before open limit

**91:02** 15 % before open limit

**91:03** 20 % before open limit

**91:04** 25 % before open limit

**91:05** 30 % before open limit

**91:06** 35 % before open limit

**91:07** 40 % before open limit

---

**92:00 Set point Close (Relay module)**

**91:00** 5 % before closed limit

**91:01** 10 % before closed limit

**91:02** 15 % before closed limit

**91:03** 20 % before closed limit

**91:04** 25 % before closed limit

**91:05** 30 % before closed limit

**91:06** 35 % before closed limit

**91:07** 40 % before closed limit

---



**Gaposa** srl - via Ete, 90 - 63900 Fermo - Italy  
T. +39.0734.220701 - F. +39.0734.226389 - [info@gaposa.com](mailto:info@gaposa.com)  
[www.gaposa.com](http://www.gaposa.com)