



QC201 230 V~

*AUTOMATIC CONTROL PANEL WITH
INTEGRATED COURTESY LIGHT*



Made in Italy



INDEX

SAFETY

WIRING

POWER

OPERATING LOGIC

RADIO TRANSMITTERS' PROGRAMMING

DEVICES

OPTOELECTRONIC BAR AND/OR PHOTOCCELL

INTEGRATED COURTESY LIGHT

AUTOMATIC CLOSING MODE

CANCELLATION OF THE AUTOMATIC CLOSING MODE

PROGRAMMING OF WORKING TIME

EMERGENCY MODE WITH FAULTY BAR

RESET

ALERTS

SAFETY



These instructions contain important information on the installation and the use of the QC201 unit. Please keep them even after installation. Do not start installing the QC201 unit without having first read these instructions. The installation can only be done by a qualified technician. In order to conform to the rules in force, the installation must include on its power supply line a differential magnetothermic switch with minimum distance between the contacts of at least 3mm. The security of the product depends on a correct installation. Be at a far distance from shutter/awnings in movement. Check frequently if any loss of balance, sign of wear or damages wires are shown. Do not use if any repairing or maintenance is needed. GAPOSA declines all responsibility in case of improper use of the product or of an incorrect installation. The product has been made respecting the European norms: 2006/95/CE (CEE73/23, CEE93/68), 2004/108/CE (CEE89/336), CEE89/106, CEE89/392, EN60335-1 04/1998, EN60204-1 09/1993, EN55014-1 4/1998.

IMPORTANT! All connections must be made while power supply is cut off!

TURN THE MAIN SWITCH OFF before any other operation!

Power supply	230 Vac \pm 10% - 50/60Hz (singlephase)
Max Motor power	800 W
Exit 24V~	terminals 11 - 12, MIN 20 Vac, MAX 26.5 V~
Exit 12Vcc	terminals 9 (+) - 3 (GND), MIN 9.5V, MAX 12.5 V
AUX exit	terminals 13 - 14, 250V - 2A, resistive load - potential-free contact NO
Frequency	433.92 MHz
Coverage (int/ext)	20 m / 200 m
Channels	62
Flashing light	230 V~ - Max 25 W (autolamping)
Protection fuse	4A (delayed)
Protection rate	IP54
Working temperature	-10°C / +50°C
Dimensions	133 x 208 x 80 mm

Maximum current (12V _{cc} / 24V~)		
Loading condition	24V~	12Vcc
Case 1	0mA	50mA
Case 2	70mA	40mA
Case 3	140mA	10mA

ELECTRICAL CONNECTION

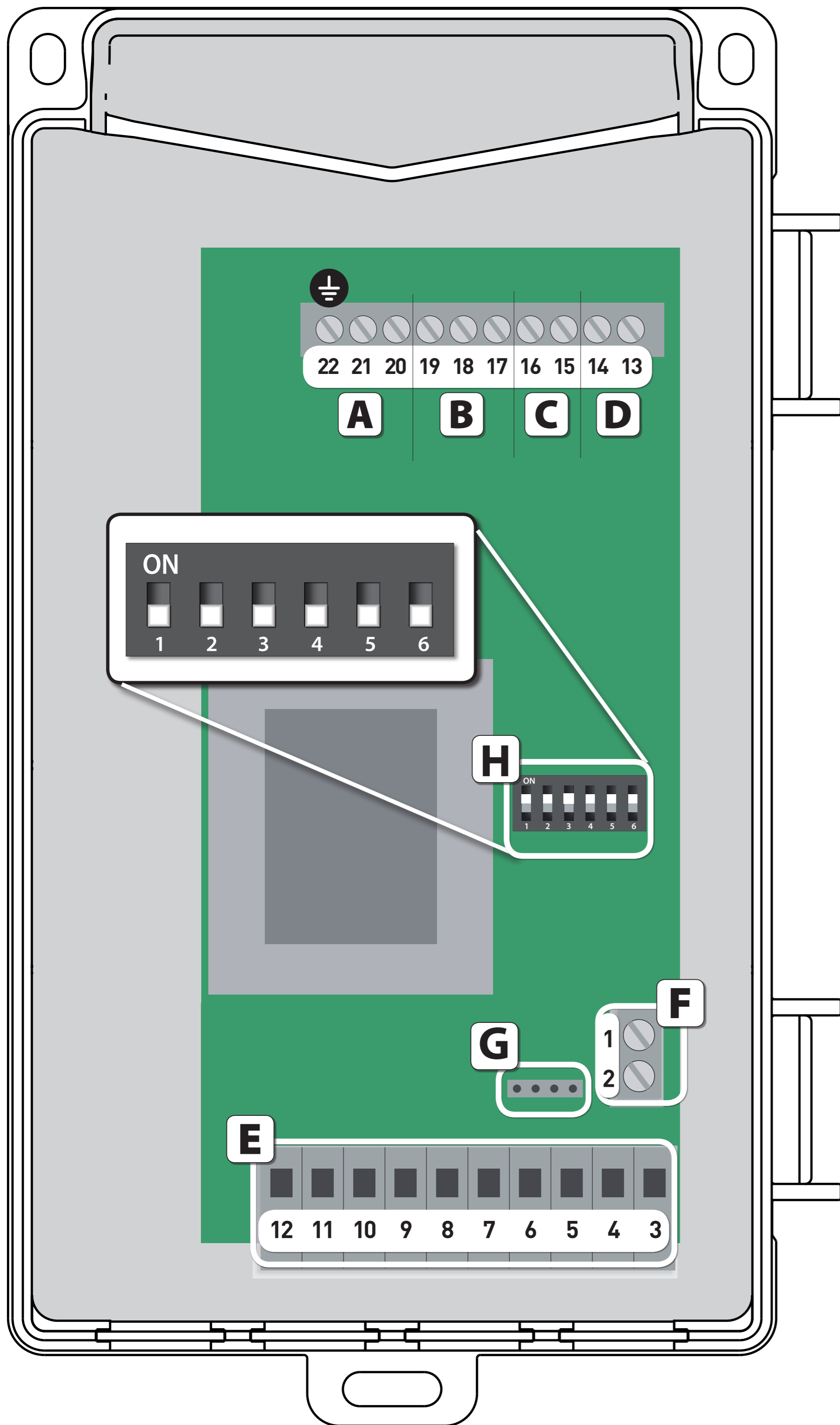

A 20 - 21 - 22 Power supply 1-phase (230 v~) (ground = 22)

B 17 - 18 - 19 Motor (COM = 18)

C 16 - 15 Flashing light [230V~]

D 14 - 13 Courtesy lamp (contact normally open - no)

12 - 11 Power supply external accessories (24 V~)

10 - 9 [COM] Safety photocells or bar (contact normally closed - nc)

8 - 9 [COM] Safety stop (contact normally closed - nc)

E 7 - 5 Start / stop (contact normally open - no)

6 - 5 Close (contact normally open - no)

4 - 5 Open (contact normally open - no)

F 1 - 2 Antenna: connect the antenna to terminal 1
In case of cable with shielding, this has to be connected to terminal 2.

G KB connector for integrated keyboard

H DIP SWITCH for control unit setup

POWER



When you activate the board the red LED switches on steadily for about 3 seconds. After about 1 second, the green LED will flash a number of times equal to the review.

When the red LED switches off, the green LED switches on steadily indicating that the switch on procedure of the card is completed and now it is ready for operation.

OPERATING LOGIC

The control unit has 2 operating logic:

- Automatic: opening and closing are automatic.
- Dead-man in closing: opening is automatic while closing is dead-man.
Note: When you activate the dead-man in closing, this will also be valid for any radio remote controls combined with the control unit

The logic of operation is selected using DIP 2 according to the following table:

OPERATING LOGIC	DIP 2
Automatic	OFF
Dead-man in closing / Automatic in opening (not for use with QCTRKP)	ON

TRANSMITTERS' PROGRAMMING



1. Place the DIP 1 in ON position. Both the red and the green LED will be switched on with a fixed light
 - 2.1 To associate a channel with a **Start/Stop** command send a signal from the transmitter.
 - 2.2 To associate a channel with an **Open** command send a signal from the transmitter while holding down the UP button on the control unit.
 - 2.3 To associate a channel with a **Stop** command send a signal from the transmitter by holding down the STOP button on the control unit.
 - 2.4 To associate a channel with a **Close** command send a signal from the transmitter by holding down the DOWN button on the control unit.
 - 2.5 To associate a channel with a command **to switch on the courtesy light** send a signal from the transmitter by holding down the UP and DOWN buttons on the control unit.
3. The LEDs will act as follows:

GREEN LED	RED LED	
FAST FLASHING	OFF	code is already memorized
OFF	FAST FLASHING	code is already memorized
FAST FLASHING	FAST FLASHING	memory is full
5 SLOW FLASHES		storing refused. Check the correct connection of the inputs

4. If further code memorization must be performed repeat step 2, otherwise place the DIP 1 in OFF.

SAFETY DEVICES



The safety of the board are managed via DIP 3 and 4:

SAFETY LOGIC	DIP 3
When an obstacle is detected during the way down the movement is reversed until the opening limit switch; It has no effect on the way up.	OFF
When an obstacle is detected during the way down the opening movement is inverted for 2 seconds and then it stops. When an obstacle is detected during the way up the movement is immediately stopped.	ON
TYPE OF SAFETY SELECTION	DIP 4
Security input for normally closed contact.	OFF
Security input for optoelectronic bar with digital signal. To be connected as follows: Mass in terminal 3, + 12V DC in terminal 9, digital signal in terminal 10.	ON

OPTOELECTRONIC BAR AND/OR PHOTOCELL



To connect the optoelectronic bar QCSE and the photocell, the latter must be connected in series to the digital signal of the bar as shown (**DIP 4 in ON**).

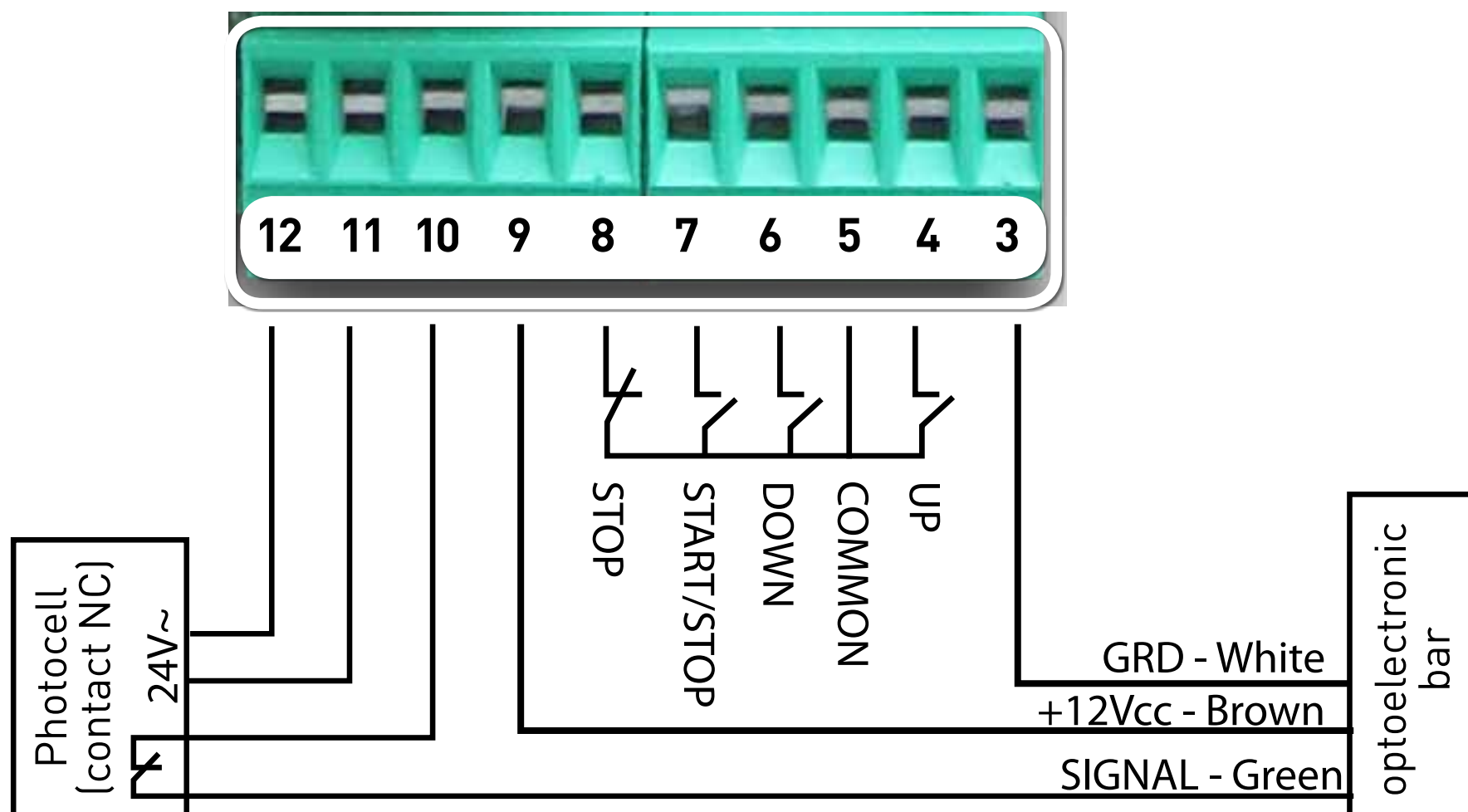

To connect the the photocell, the latter must be connected as shown (**DIP 4 in OFF**).

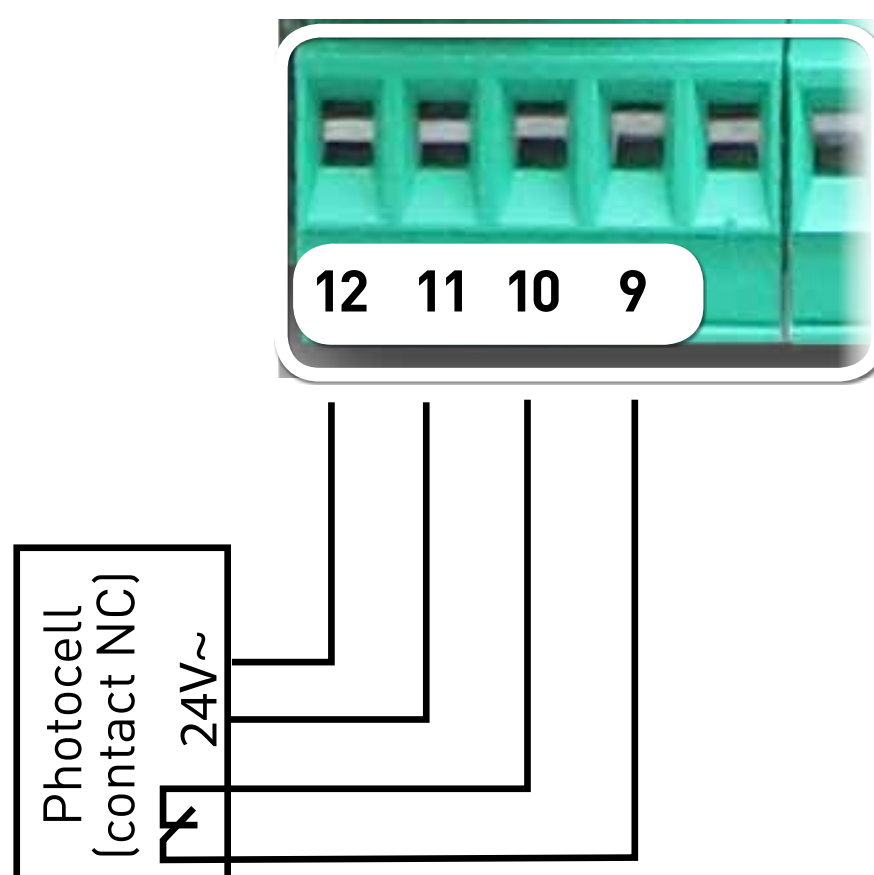

INTEGRATED COURTESY LIGHT



The courtesy lamp contact will activate itself, after an opening input, once the door is completely closed and the operation time over.

The contact of the courtesy light has two working modes:

- switch on in case of opening and automatic switch off after 3 minutes
- switch on for two seconds while opening (useful to operate a lighting system).

In order to switch from one mode to the other, please move the dip 2 on ON and then on OFF for at least three times

NOTE: you should move consecutively from OFF to ON within 2 seconds, otherwise the number of movements will be reset to zero).

The leds will inform you about the selected mode:

- Activation of mode 3 minutes: green led ON, red led flashing slowly for 3 seconds
- Activation of mode 2 seconds: green led ON, red led flashing quickly for 3 seconds

In case the courtesy light is matched with a radio code, the transmission of the command will cause the activation of the relé for 3 minutes or 2 seconds according to the control unit programming. In case of transmission of the command with active relé, it will be deactivated.

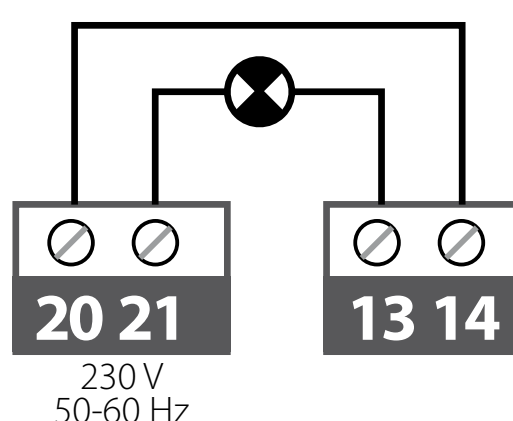

AUTOMATIC CLOSING MODE



The control includes, among its functions, the automatic closing after a set time.

The automatic closing activates by programming the pause time and by choosing the “impulse” operating mode (DIP 2 in OFF). When the dead-man logic is active while closing, the automatic closing is excluded (DIP 2 in ON).

In order to program the pause time it is necessary:

1. To put DIP 5 and 6 in OFF
2. To put DIP 5 in ON. The green LED will switch off and make a short flash every second.
3. Wait for the pause time you want to program (the time must be greater than 5 seconds, for a maximum of 4 minutes)
4. After the required time replace the DIP 5 in OFF. If programming is correct, the green LED will flash quickly and then remains lit.

ADDITIONAL NOTE: The time count for the automatic closing starts when the opening movement is interrupted by the **START/STOP** command or the intervention of the limit switch in opening; the counting of the pause is notified via a short cut off of the green LED every 3 seconds.

While in pause, a START/STOP control excludes the automatic closing; a further START/STOP control closes the door. By pushing the STOP control the automatic closing is excluded.

The automatic reclosure is excluded (even if programmed) if:

- a safety system intervenes (safety stop, photocell, bar, motor thermal efficiency etc.)
- the dead-man logic is activated in closing
- a closing movement is interrupted.

CANCELLATION OF THE AUTOMATIC CLOSING MODE



This procedure clears the pause time and then excludes the automatic closing.

1. Put DIP 5 and 6 in OFF
2. Put DIP 5 in ON and within 3 seconds put it again in OFF.

**If cancellation has been accomplished correctly, the red LED will flash quickly and then switch off.
Then the green LED will switch on steady.**

PROGRAMMING OF WORKING TIME



The work time is the time it takes to perform a complete opening or closing operation. By performing this procedure the board automatically learns the stroke. Without programming, the working time lasts 30 sec.

ATTENTION: During the programming procedure ensure that no obstacle activates the safety devices (photocells or safety edges) and stops the movement of the door. If that happens, it is necessary to proceed with a new programming cycle of the working time (close the current programming, perform the RESET and proceed with a new cycle).

In order to program the working time, you must:

1. Test the motor phases and check that the limit switches are calibrated and connected properly! If during the procedure the safety systems intervene, the movement of the motor stops.
2. Place the door halfway.
3. Put DIP 5 and 6 in OFF.
4. Put DIP 6 in ON. The red LED will switch on.
5. Give a START/STOP signal (terminal 7), the door starts to open. When opening is complete send a new START/STOP signal.
6. Give a START/STOP signal (terminal 7), the door starts to close. When closing is complete send a new START/STOP signal.
7. Set DIP 6 in OFF. The red LED will switch off indicating the end of the programming procedure.

NOTE: In order to ensure the complete closing and opening under all conditions, the control unit automatically adds 4 seconds to the programmed time.

EMERGENCY MODE WITH FAULTY BAR



This mode allows the movement of the motor with dead-man control also in case the optoelectronic bar is active or faulty.

Mode description:

- The mode becomes operational after about 30 seconds from the coast activation (the count is reset if the bar returns to visibility)
- The mode allows the movement of the motor in opening and closing in dead-man mode regardless of the position of the dip 2.
- The movement of the motor during this mode is automatically stopped after 5 seconds. The movement can be resumed by pressing the command again.

Mode activation:

1. Put dip 6 in ON
2. Move dip 3 at least 3 times from ON to OFF (between two OFF-ON consecutive steps shall not be more than 2 seconds or the movements count is reset)
3. If the change is activated, the red and green LEDs will flash quickly for about 4 seconds
4. Put dip 6 back in OFF

Once the mode activated, it will be actually present only in case dip 3 and 4 are in ON (safety active also in opening and optoelectronic bar active). Otherwise, the mode is not operational even if enabled.

Mode disabling:

The mode can be disabled exclusively by the reset procedure (see procedure).

RESET



Through the reset procedure:

- all memorised transmitters will be deleted
- the programming of pause time and of the stroke are reset to default conditions (working time of 30 seconds, automatic closing disabled).
- the “Emergency mode with faulty bar” is also turned off.

During the reset procedure, all controls are inhibited.

To reset the control unit, you must:

1. Place all DIP in OFF
2. Place DIP 5 and 6 in ON
3. The green LED will switch off while the red one will start flashing rapidly. After the reset, the red LED switches off while the green LED will start making three quick flashes every 3 seconds.
4. Place DIP 5 and 6 in OFF. The green LED will remain ON and steady and the reset procedure is completed.
5. You can now reposition the DIP according to the desired functions.

ALERTS



The following table shows the various light signals generated by the control unit with their meaning and possible operations to be performed.

CONTROL UNIT FEEDBACK

CONTROL UNIT STATUS	GREEN LED	RED LED	SOLUTION
READY FOR COMMANDS EXECUTION	ON	OFF	-
WAITING FOR AUTOMATIC CLOSING	SHORT SHUTDOWN EVERY 3 SECONDS	OFF	-
MOTOR UPWARDS	SLOW FLASHING WITH DUTY CYCLE 50%	OFF	-
MOTOR DOWNWARDS	FAST FLASHING WITH DUTY CYCLE 50%	OFF	-
PAUSE TIME PROGRAMMING	SHORT FLASHING EVERY SECOND	OFF	SEE PROCEDURE 5.1
WORKING TIME PROGRAMMING	ON	ON	SEE PROCEDURE 5.3
RESET IN PROGRESS	3 CLOSE FLASHINGS EVERY 3 SECONDS	OFF	PUT DIP 5 AND 6 IN OFF

TROUBLESHOOTING

RED LED	ERROR SOLVING
1 FLASH	CHECK THE STOP BUTTON CONNECTIONS
2 FLASHES	CHECK THE SAFETY DEVICES CONNECTIONS / CHECK SAFETY ACTIVATION
8 FLASHES	CHECK: <ul style="list-style-type: none"> • POWER SUPPLY • OVERLOAD OUTPUT 12V (TERMINALS 9-3) • OVERLOAD OUTPUT 24Vac (TERMINALS 11-12)
LED SWITCHES ON STEADILY	WRONG DIPS SETTING, FOLLOW THE BELOW PROCEDURE: <ol style="list-style-type: none"> 1. SET ALL DIPS IN OFF POSITION 2. WAIT FOR 5 SECONDS 3. SET THE DIPS IN THE DESIRED POSITION FOLLOWING THE INSTRUCTIONS



GAPOSA srl - via Ete, 90
63900 Fermo - Italy
T. +39.0734.220701 - info@gaposa.com

