

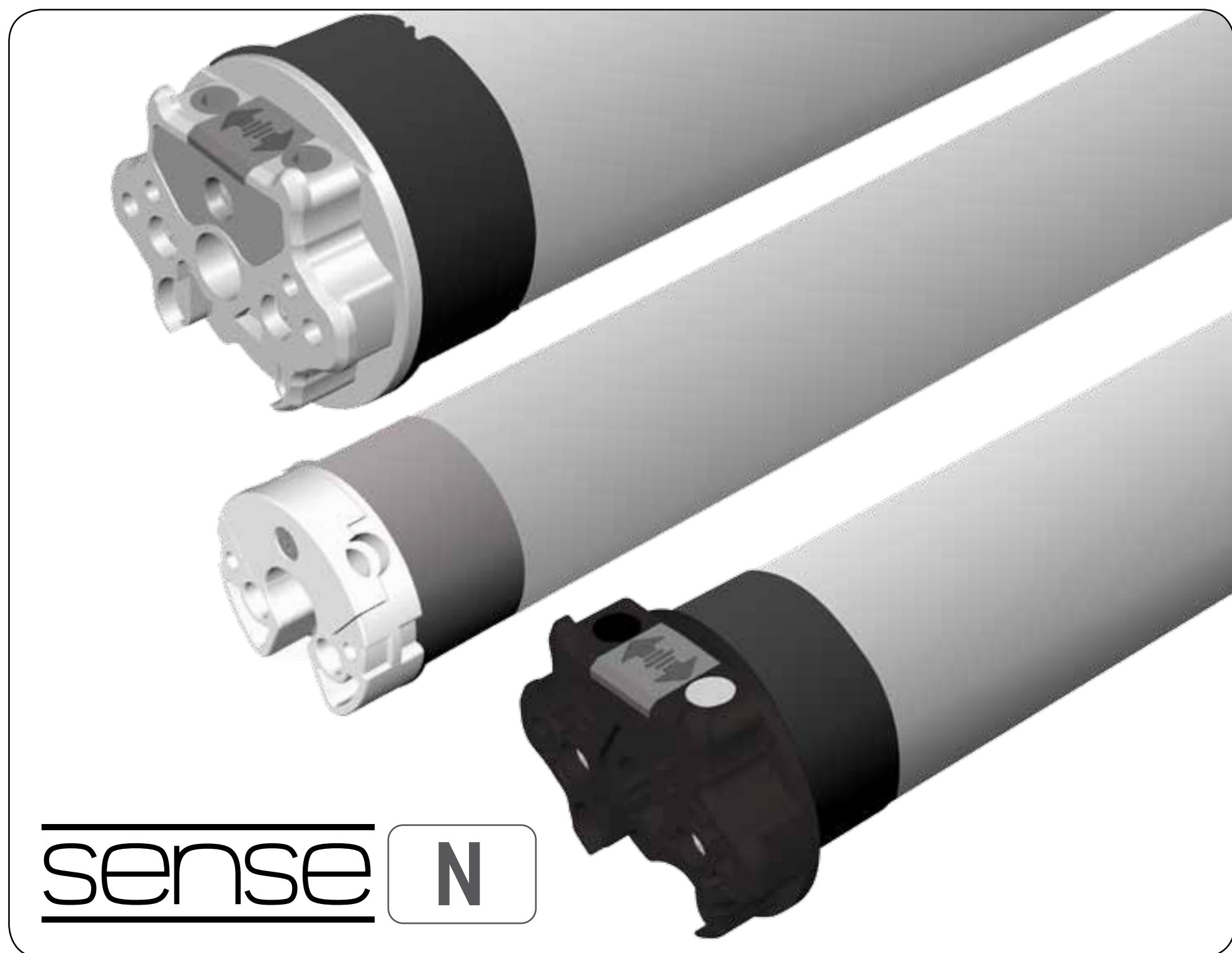

XQ 40 50 60

*TUBULAR MOTORS WITH OBSTACLE
DETECTION AND AUTOMATIC LIMIT SETTING*



Made in Italy



INDEX

SAFETY

INSTALLATION

ELECTRICAL CONNECTION

PROGRAMMING

AUTOMATIC LIMIT SETTING

MANUAL LIMIT SETTING

DEACTIVATING OBSTACLE SENSITIVITY

ACTIVATING OBSTACLE SENSITIVITY



**CAREFULLY FOLLOW THESE INSTRUCTIONS.
IT IS VERY IMPORTANT FOR THE SAFETY OF
PERSONS. SAVE THESE INSTRUCTIONS.
IMPORTANT:**

- Check the shutter/awning in motion and keep persons far from it while in action.
- Frequently check if any loss of balance, signs of wear or damaged wires are shown.
- Do not use if any repairing or maintenance is needed.
- In case of installation in awnings keep a distance of at least 0,4 m from it (completely open) and whatever fixed item in the nearby.
- The device is not intended to be used by people (including children) whose physical, sensory or mental capabilities are reduced, or lacking experience or knowledge, unless they have been granted through the intermediary of a person responsible for their safety, supervision or instruction concerning the use of the device.
- Children should be supervised to ensure they do not play with the device and / or with fix control devices.
- The control devices installed in a fixed manner must be positioned in view.

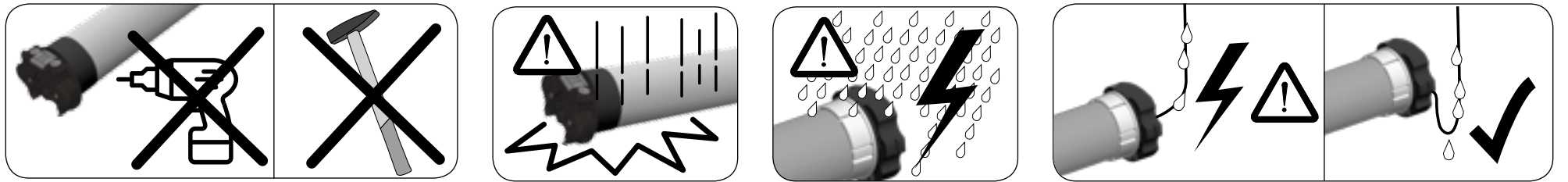

To complete installation, the motor must be provided with a couple of adaptors (corresponding with the tube) and a fixing bracket. For a list of the available accessories, refer to the catalogue.

WARNING: incorrect installation can cause serious injuries. Follow the installation instructions. Before you remove all unnecessary cables and turn off any equipment not required for this operation.

1

Fix the adaptors to the motor distinguishing the limits ring (A) from the drive pulley (B).



2

Insert the motor (E) into the tube (F) until its end stops against the limits ring.





- 3** The fixing bracket (C) must be fixed inside the box or on the awning frame so that the roller tube (F) is perfectly horizontal and at a height not less than 1,8m.

- 4** **[FOR XQ50]** Place the motor square pin (D) on the bracket (C) and the cap at the opposite end of the tube on the fixing plate.
WARNING: Never hit on the head of the motor (D) when you insert it into the tube.

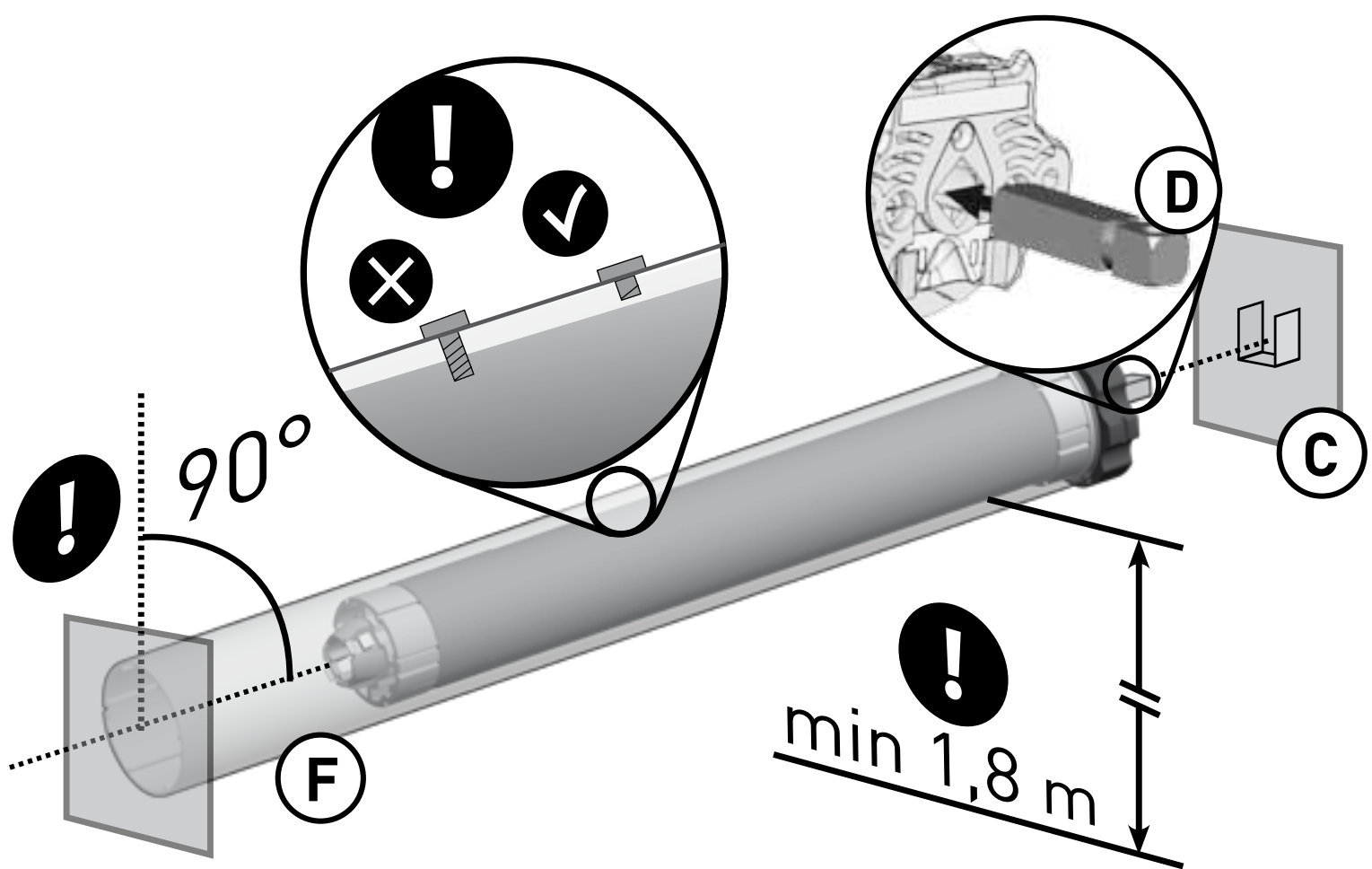

NOTES

- For the XQ50, with torque up to 15Nm, the minimum tube diameter is 50x1,5mm; for motors with higher torques, the minimum tube diameter is 60x1,5mm.
- For the XQ60, the minimum tube diameter is 63x1,5mm.

WARNING:

- The screws used to fix the last slat on the tube may be too long and reach the tubular part of the motor. Use appropriate screws or fixing clips.
- Motor moving parts installed under 2,5m from the ground must be protected.
- A wrong motor installation can damage persons or objects.

ELECTRICAL CONNECTION



Check that the mains voltage available on the system is as shown on the label. The motor mains connection should be executed according to the diagram on the next page, by qualified technicians able to operate in compliance with the rules.

ATTENTION: The power supply must contemplate a switching device with an opening distance between contacts of at least 3mm.

The motors connecting cables to the network can only be replaced with cables of the same type provided by the motor manufacturer.

- Do not connect more than one tubular motor to a single switch.
- Do not set the shutter/awning into motion while you are cleaning or servicing the device and disconnect the supply.
- The switch controlling the motor must be installed in full view, not higher than 1,5m and it must be kept far from moving parts.

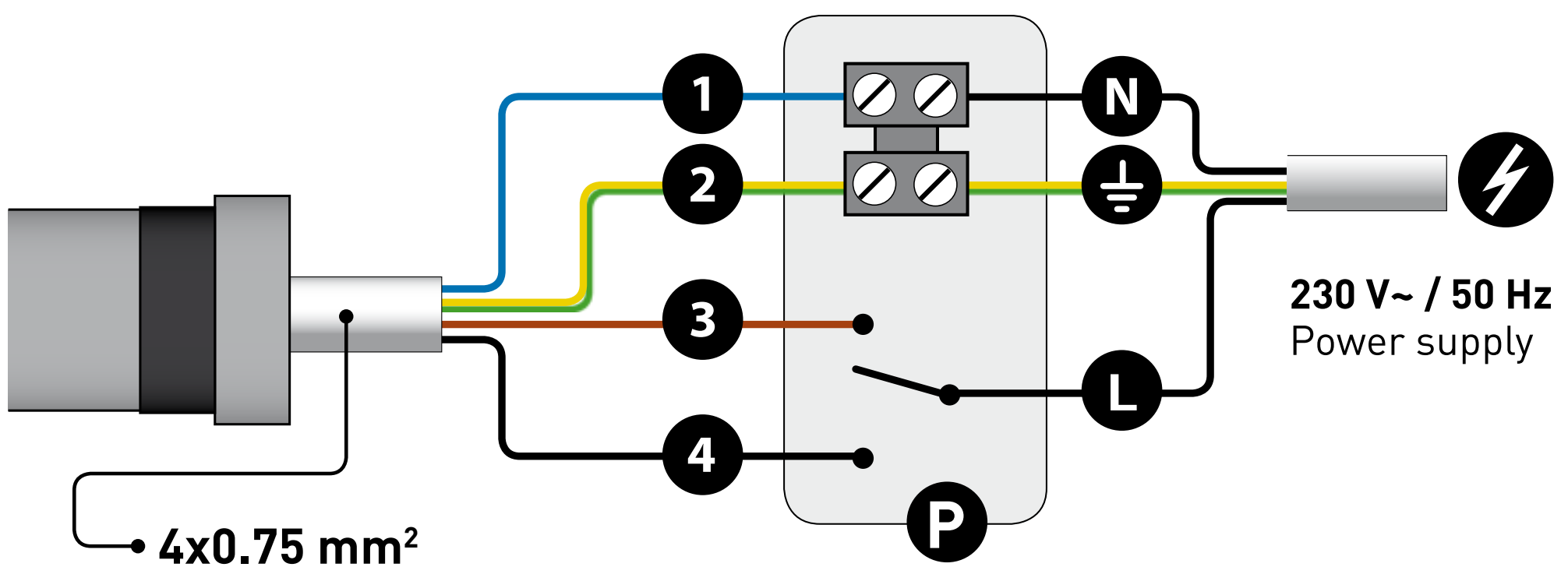

1	Neutral	Blue
2	Ground	Yellow/Green
3	Direction of rotation 1	Brown
4	Direction of rotation 2	Black

N	Neutral
⏚	Ground
L	Phase
P	Push button



NOTE: For the auto limits setting it is required that the roller shutter features a bottom bar capable to stop the screen at the up end position.

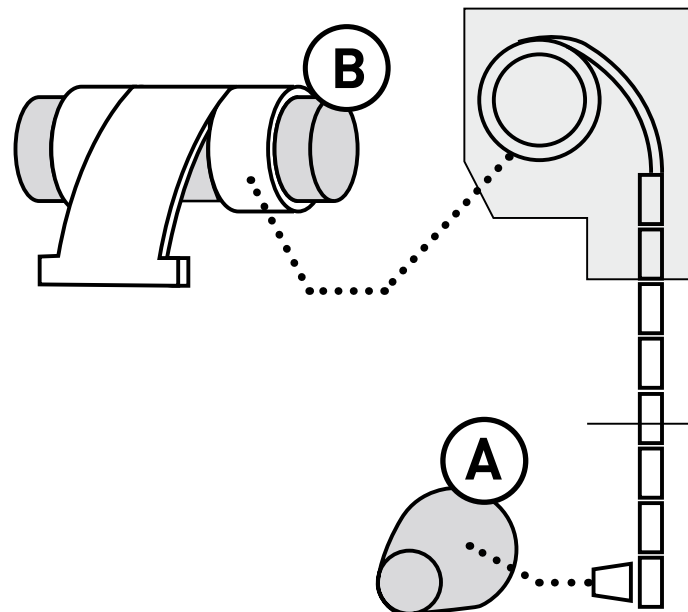

OPTION 1

Use the setting switch device ACPRET

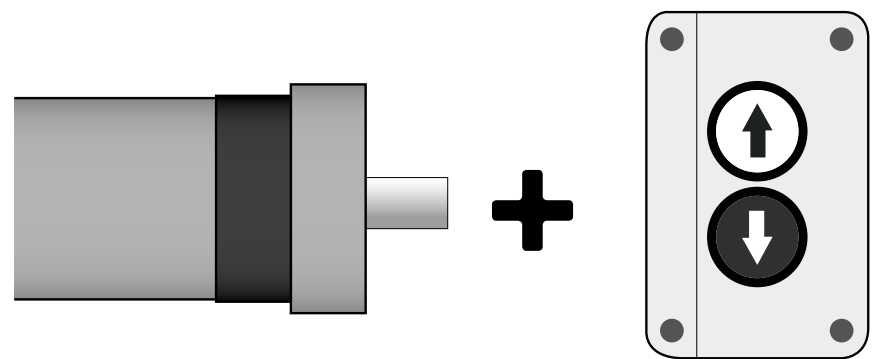

ACPRET

Pressing and holding Up and Down buttons together till the motor jogs

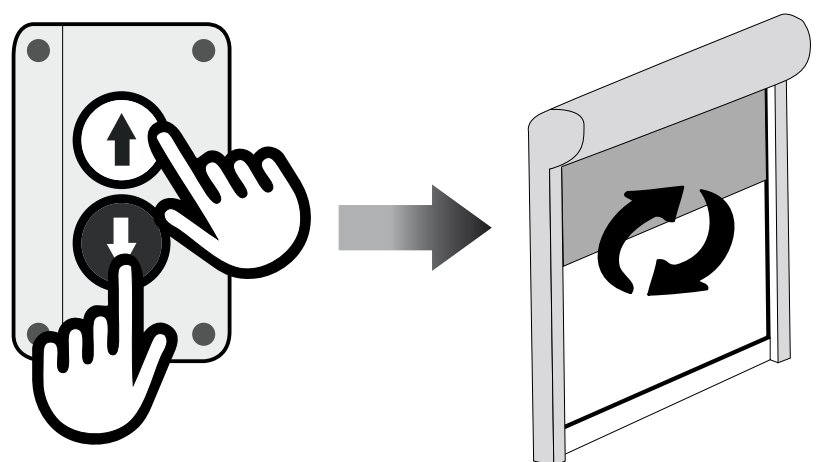



OPTION 2

Use any standard push button

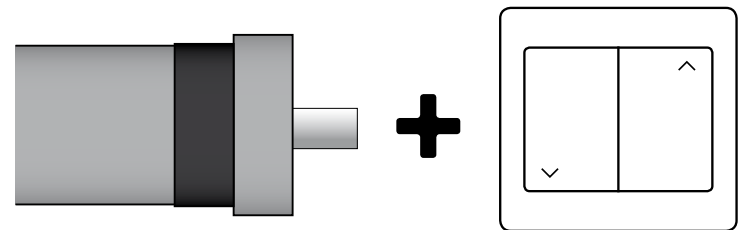

1

Press the Up button and release it as soon as the motor starts running for 3 times

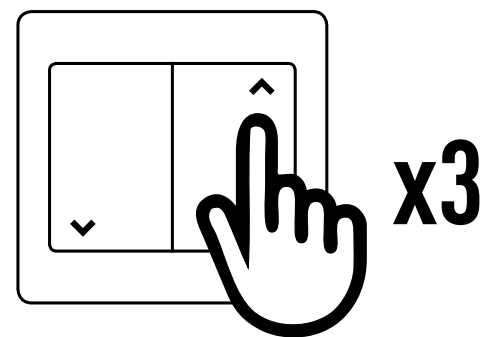

2

Press the Down button and release it as soon as the motor starts running for 2 times

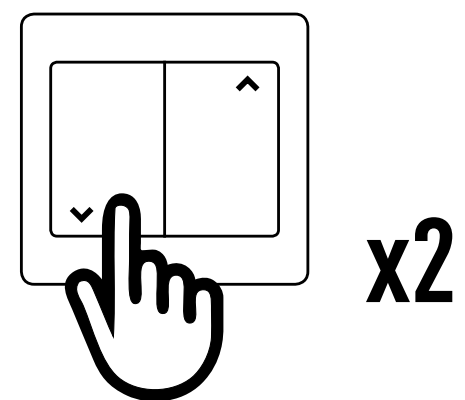

3

Press and hold the Down button for the 3rd time till the motor makes a jog. The motor is now in programming mode

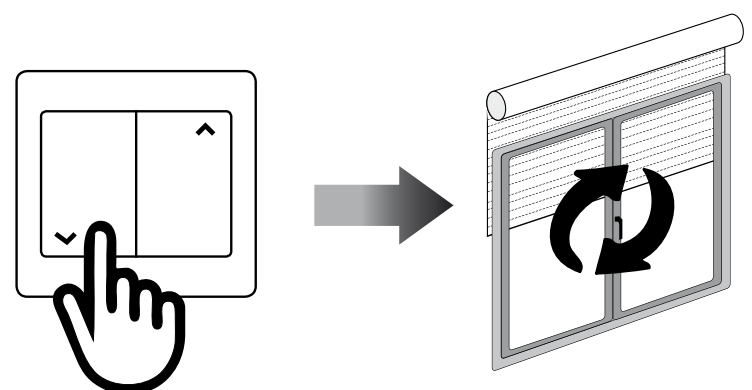

Note: you can understand that the motor is in programming mode by a brief start & stop of the motor while running.

AUTOMATIC LIMIT SETTING



1

Press and hold the UP button for more than 2 seconds then release.

The motor runs upward to the TOP limit, stops itself (because the bottom bar beats against the cassette) and sets the TOP limit. After few seconds it starts running automatically downwards to self-set the BOTTOM limit. When the roller shutter is completely closed the motor stops setting the BOTTOM limit

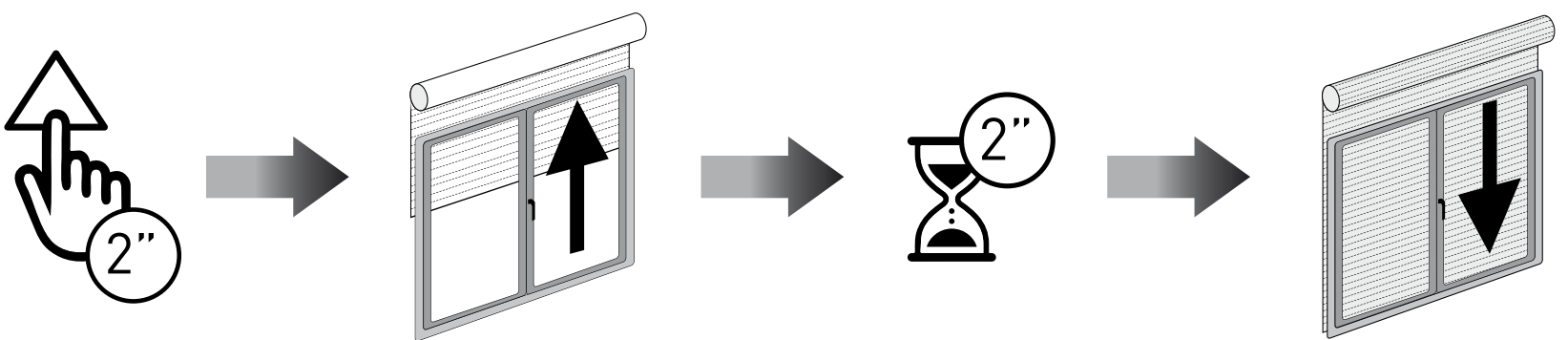

2

To double check make a full TOP/BOTTOM cycle of the roller shutter

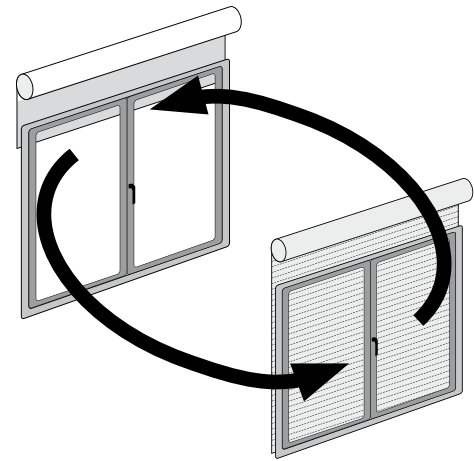



The setting switch device ACPRET is required (the UP and DOWN buttons can be pushed simultaneously).

1

Push the UP and DOWN buttons simultaneously till the motor makes a jog

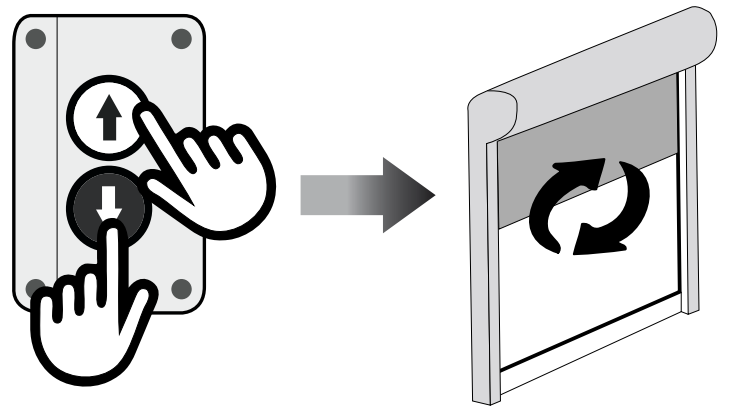

UP LIMIT POSITION

2a

OPTION 1

Keep pushing the UP button till the motor goes against the top stop setting the UP limit

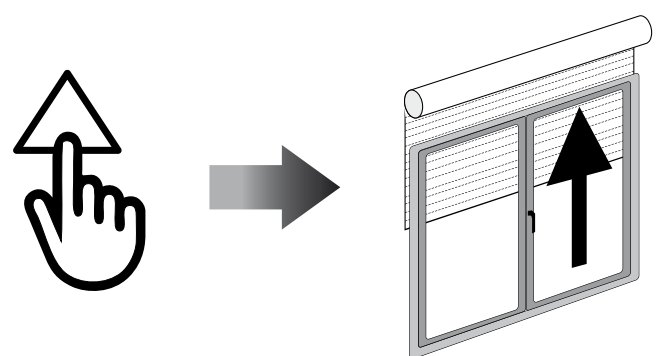

2b

OPTION 2

Move the motor to the UP limit position then push the UP and DOWN buttons simultaneously till the motor makes a jog. The UP end limit position is now set.

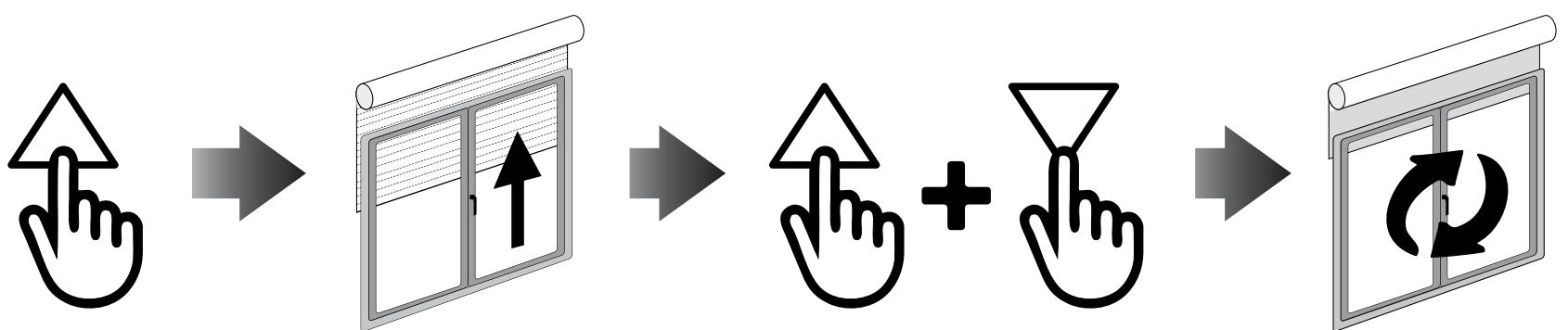

▼ DOWN LIMIT POSITION



DOWN LIMIT POSITION

1

Push the DOWN button and move the motor to the bottom end limit. Push the UP and DOWN buttons simultaneously till the motor makes a jog. The DOWN end limit position is set.

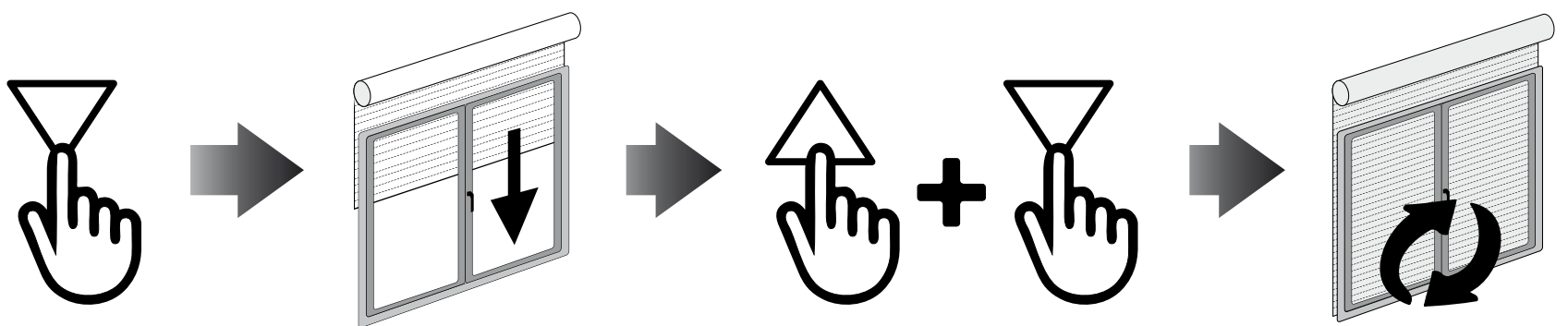

2

To double check make a full TOP/BOTTOM cycle of the roller shutter

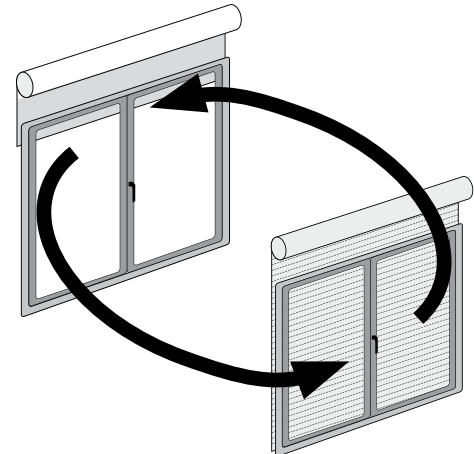

DEACTIVATING OBSTACLE SENSITIVITY



1	Press UP button	
2	As soon as the motor runs upward press DOWN button	
3	As soon as the motor runs downward press UP button	
4	As soon as the motor runs upward press DOWN button	
5	As soon as the motor runs downward press UP button	
6	When the motor runs upward press and hold DOWN button until you get 1 jog as confirmation of deactivation.	

▼ ACTIVATING OBSTACLE SENSITIVITY

ACTIVATING OBSTACLE SENSITIVITY



1	Press UP button	
2	As soon as the motor runs upward press DOWN button	
3	As soon as the motor runs downward press UP button	
4	As soon as the motor runs upward press DOWN button	
5	As soon as the motor runs downward press UP button	
6	When the motor runs upward press and hold DOWN button until you get 2 jog as confirmation of activation.	

