



## **XSDC4 EX B**

*Electronic encoded type motor with built-in radio receiver and Li-Ion battery*

## **XSDC4 EX**

*Electronic encoded type motor with built-in radio receiver*

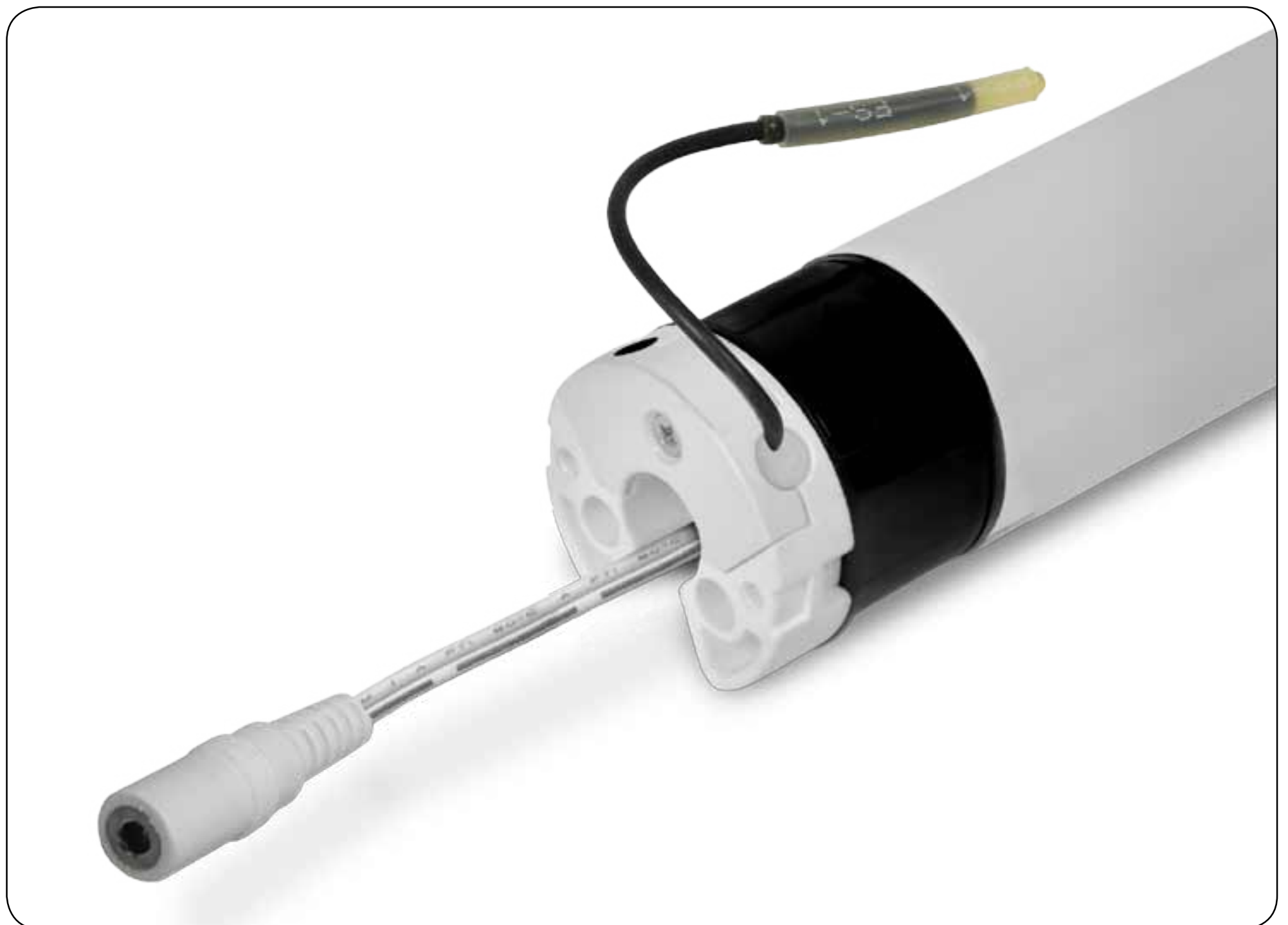

**Made in Italy**



---

# INDEX

**SAFETY**

**INSTALLATION**

**ELECTRICAL CONNECTION**

**SLEEP MODE**

**PROGRAMMING TRANSMITTER**

**ADDING TRANSMITTER**

**CHECKING/CHANGING DIRECTION**

**ERASING TRANSMITTER**

**RESET MOTOR MEMORY**

**LIMIT SWITCH SETUP**

**INTERMEDIATE POSITION**

---

# SAFETY



**CAREFULLY FOLLOW THESE INSTRUCTIONS. IT IS VERY IMPORTANT FOR THE SAFETY OF PERSONS. SAVE THESE INSTRUCTIONS. IMPORTANT:**

- Check the shutter/awning in motion and keep persons far from it while in action.
- Frequently check if any loss of balance, signs of wear or damaged wires are shown.
- Do not use if any repairing or maintenance is needed.
- In case of installation in awnings keep a distance of at least 0,4 m from it (completely open) and whatever fixed item in the nearby.
- The device is not intended to be used by people (including children) whose physical, sensory or mental capabilities are reduced, or lacking experience or knowledge, unless they have been granted through the intermediary of a person responsible for their safety, supervision or instruction concerning the use of the device.
- Children should be supervised to ensure they do not play with the device and / or with fix control devices.
- The control devices installed in a fixed manner must be positioned in view.

**ATTENTION: Damaged electric products and batteries should not be disposed of with normal household waste. Make sure to drop them in special provided containers or at an authorized organization that will ensure they are recycled.**

# INSTALLATION

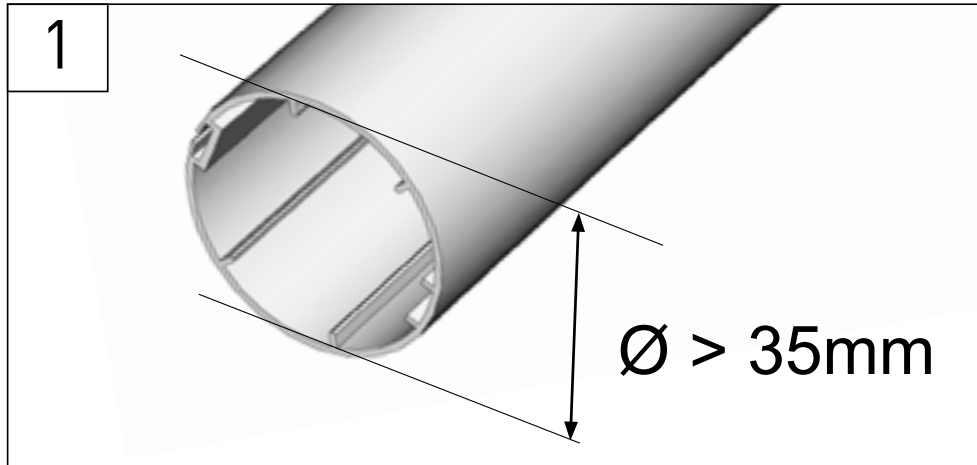

Check that the inner diameter of the tube is greater than 35mm.

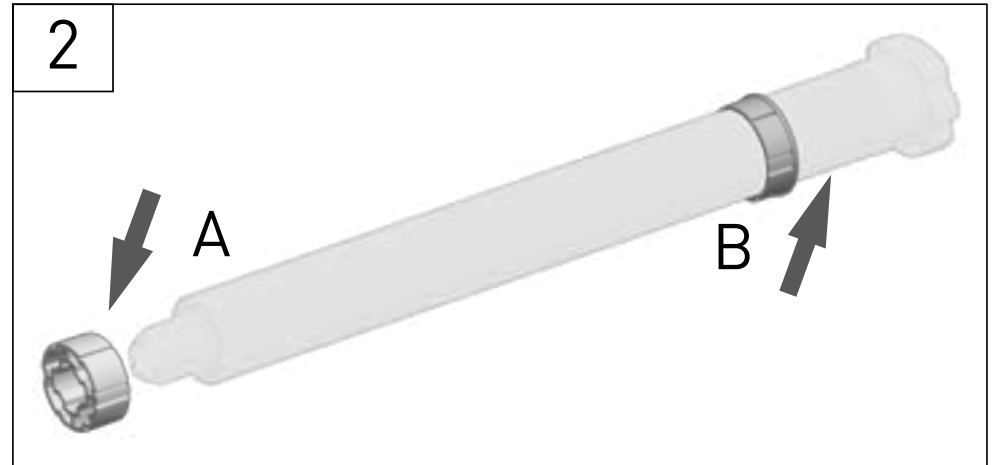

Insert the adaptors that will fit the roller tube: insert the crown (A) and the motor drive wheel (B) on the motor.

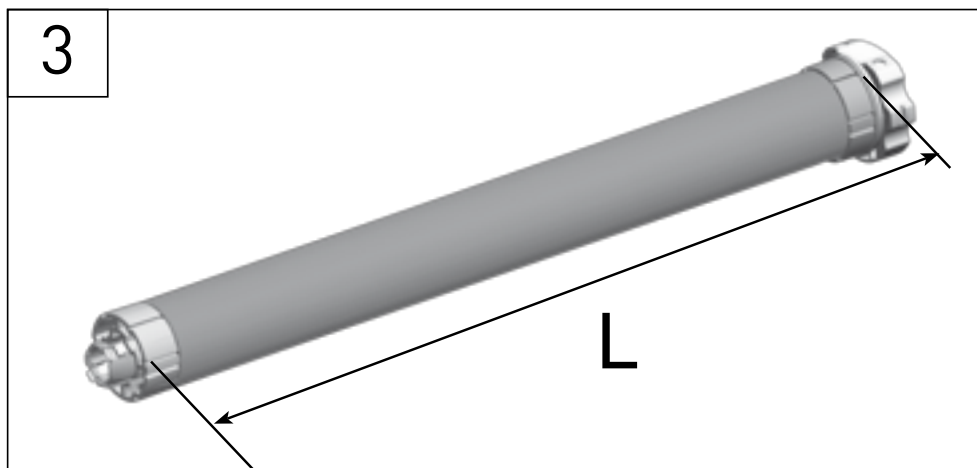

Measure the length (L) between the inner edge of the motor head and the edge of the motor drive wheel.

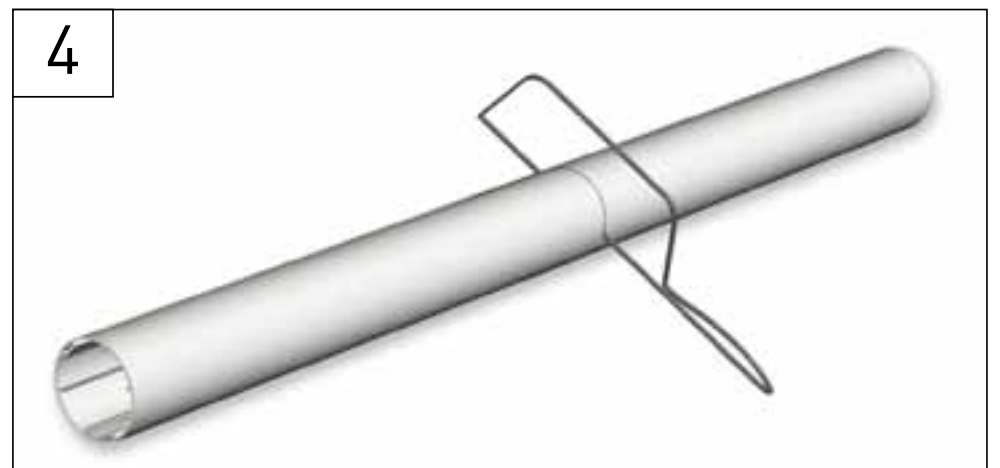

Cut and deburr the roller tube to the required length and remove the swarf.

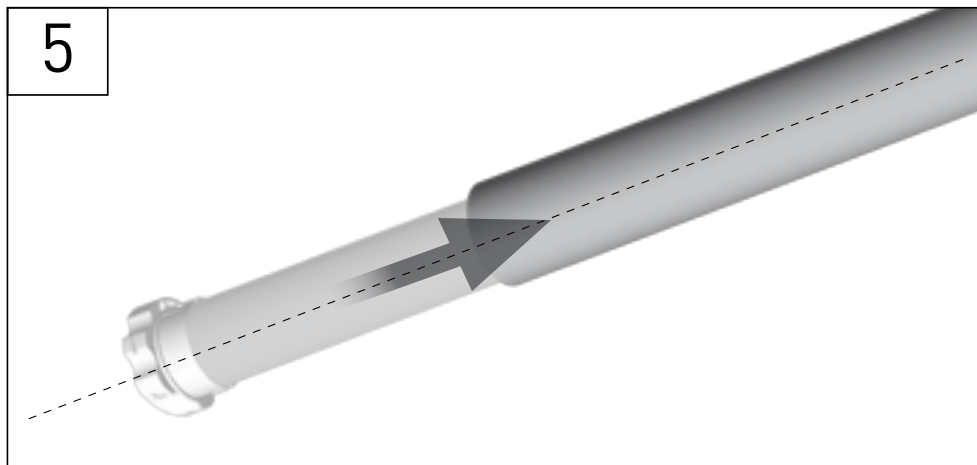

Slide the motor into the roller tube

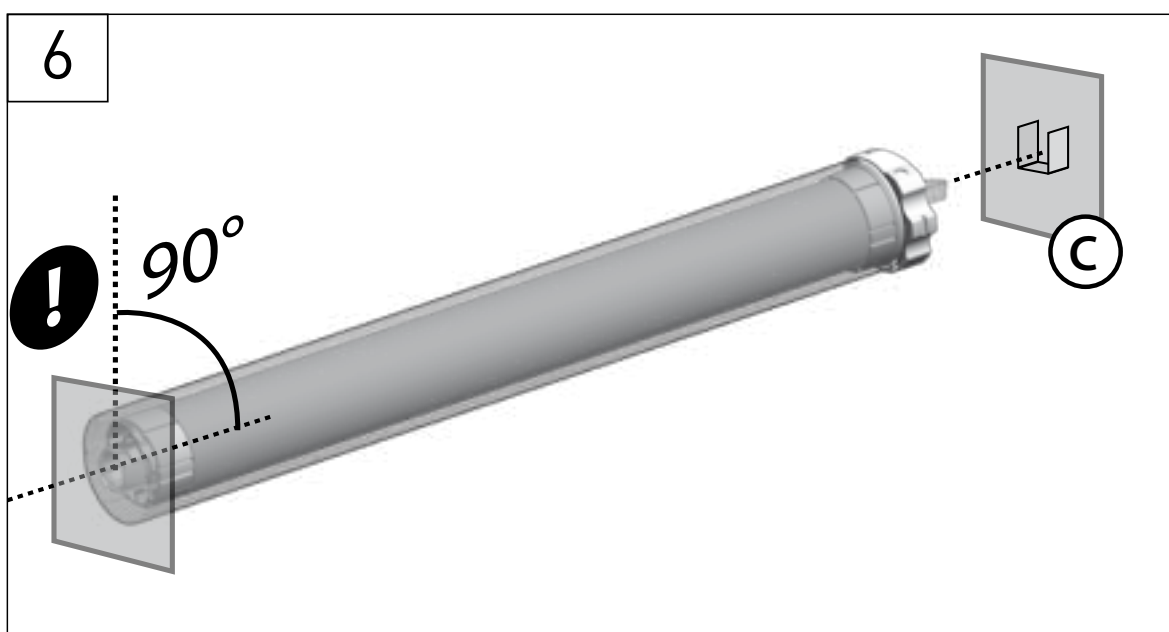

Place the motor on the bracket (C) and the opposite end of the tube on the fixing plate. Never hit on the head of the motor when you insert it into the tube.



## LI-ION BATTERY MOTORS

**ATTENTION:** Ensure battery is fully charged prior to installation. **IT IS NOT SHIPPED FULLY CHARGED** Battery comes 30 percent charged from the factory. Use power charger (recommended by Gapos) to charge the integrated Li-Ion battery.

1. Plug charger into a power outlet
2. Connect the charger to the motor power cable
3. LED light on charger will show the status:
  - Solid Red = charging
  - Solid Green = Charging is complete
4. When charging is complete (time is about 3.5 h), disconnect and store charger for later use

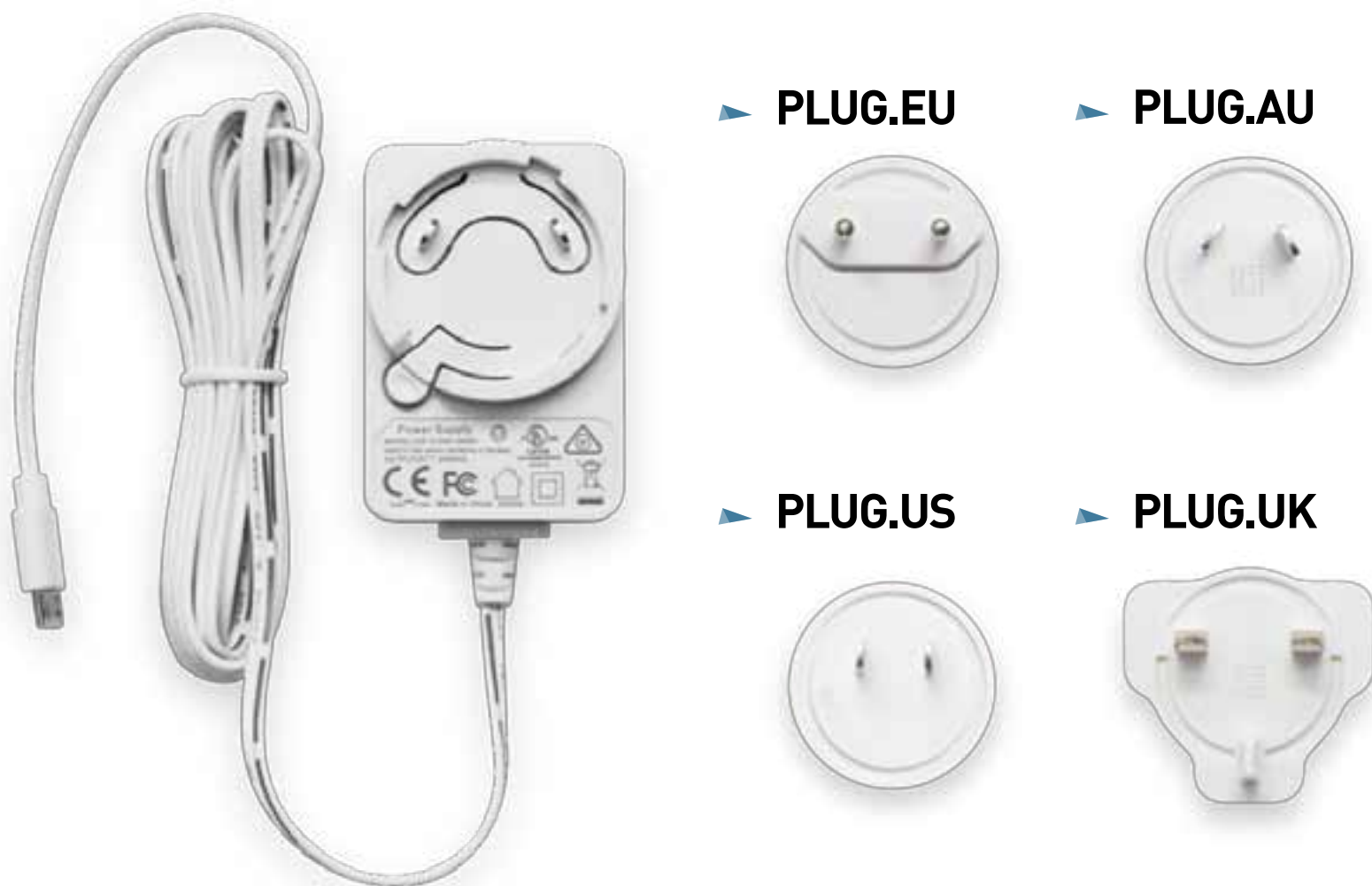

Battery charger (cod. BC12)

Input: 100-240 VAC - 50/60 Hz - 0.5 A Max

Output: 12.6 VDC - 1000 mA

Dimensions: 40 x 58 x 32 mm

Cable length: 300 cm



## POWER OPERATED MOTOR

1. Plug the power supply into a power outlet
2. Plug the power supply into the motor

### CAUTION

- Ensure cable is kept clear of fabric
- Ensure antenna is kept straight and away from metal objects

### NOTES

- Cables which pass through a metal wall must be protected and isolated using a grommet or sleeve.
- Attach cables with intent to prevent any contact with moving parts. Leave the motor power supply cable accessible: it must be possible to replace it easily.



▶ PLUG.EU



▶ PLUG.AU



▶ PLUG.US



▶ PLUG.UK



Switching power supply  
(cod. TRASDC3)

Input: 100-240 VAC - 50/60 Hz - 1.5 A Max

Output: 24 VDC - 2.0 A

Dimensions: 46 x 88 x 38 mm

Cable length: 300 cm

# SLEEP MODE



## (only for Li-Ion battery motor)

Sleep mode is a status which prevents a motor from moving during shipping or assembling:

### Wake up the motor

click the push button on the head of the motor the motor makes 1 jog

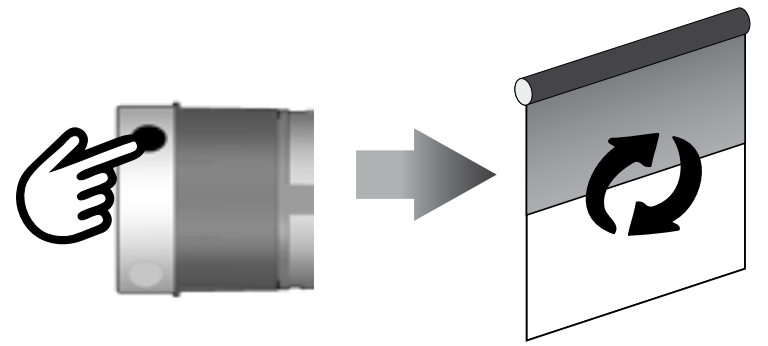

### Activate sleeping mode

click the push button on the head of the motor the motor makes 2 jogs

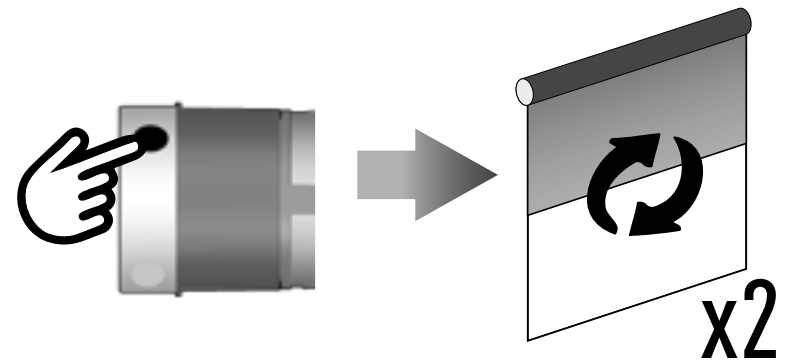

Note: any short press of the button on the head of the motor will either wake up the motor or activate sleeping mode sequentially.

**ATTENTION:** In an installation of more than one XSDC battery motors wake up one motor at a time in order to pair it to its own transmitter.



## PROGRAMMING TRANSMITTER

**1**

Press and hold the PROG-TX button (on the back of transmitter or on the head of the motor) until the motor starts moving

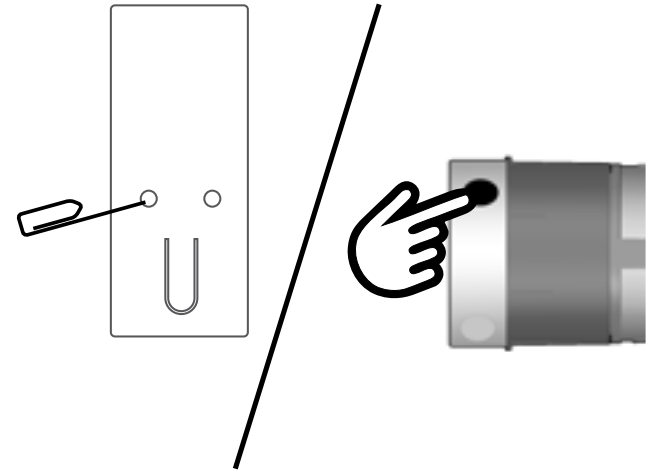

**2**

Check the motor rotation then release the PROG-TX button (the motor stops)

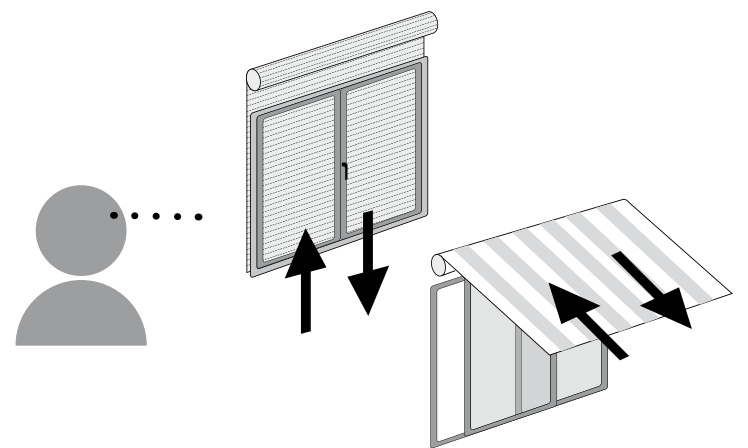

**3**

Within 5 seconds, press the corresponding button (UP if the motor turns upwards or DOWN if the motor turns downwards). Transmitter is now programmed.

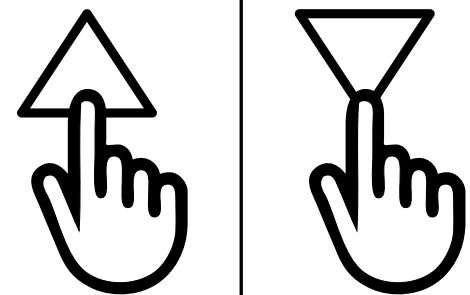





## ADDING TRANSMITTER

1

Press and Hold the PROG-TX button of a transmitter **already paired** until the motor starts moving.

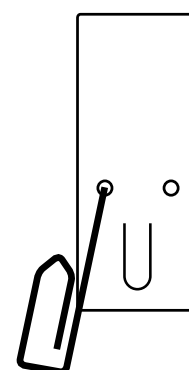

2

Check the rotation of the motor, then release the PROG-TX button (the motor stops).

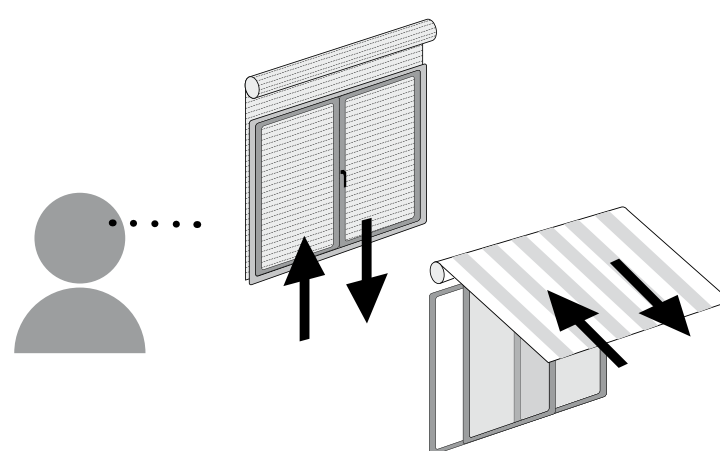

3

Within 5 seconds press the corresponding button (i.e. UP if the motor rotates upwards or DOWN if vice versa) on the **new transmitter being added**.

The new transmitter has been programmed and the rotation of the motor has been synchronized.

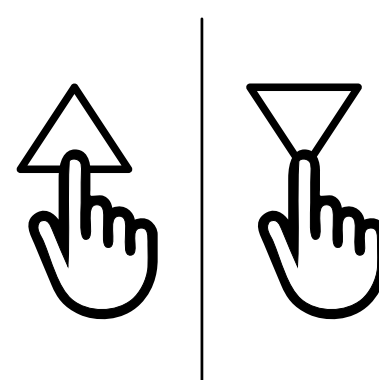

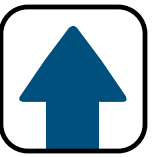

## CHECKING/CHANGING DIRECTION

**IMPORTANT:** change direction must be performed before starting limit setting otherwise limits must be reset.

Press UP or DOWN the motor should go UP or DOWN, otherwise to change direction:

1

Press and hold the PROG-TX button until the motor starts moving

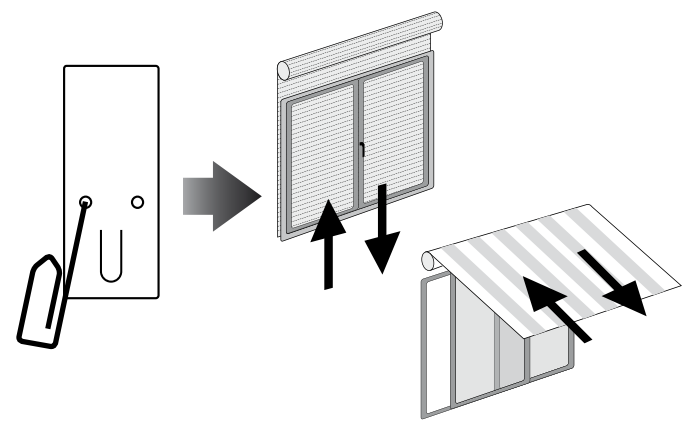

2

Press STOP: The motor makes a brief jog. Direction of the motor has been reversed.

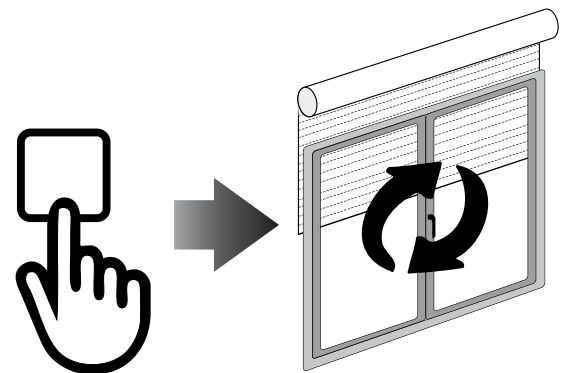

## ERASING TRANSMITTER

Push simultaneously the PROG-TX button and STOP of the transmitter until the motor makes a brief movement in both directions.

Only the transmitter used for this procedure has been deleted from motor memory.

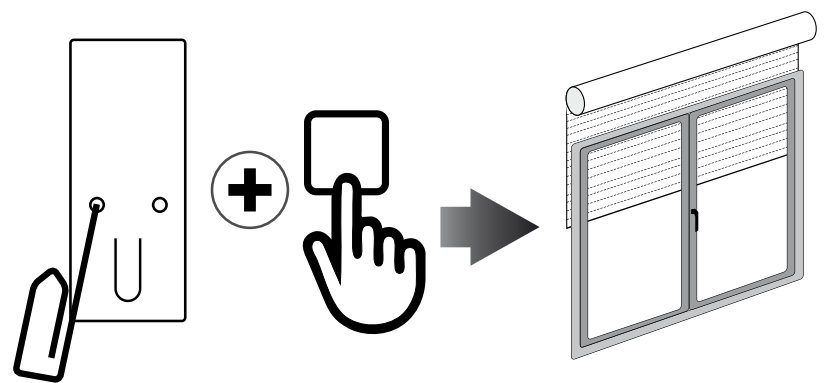



## RESET MOTOR MEMORY FOR POWER OPERATED MOTOR

### OPTION 1 - Using an already programmed transmitter

Press and hold both the PROG-TX and STOP buttons until the motor makes first a brief jog and, after a while, a second, long jog. Memory is now empty.

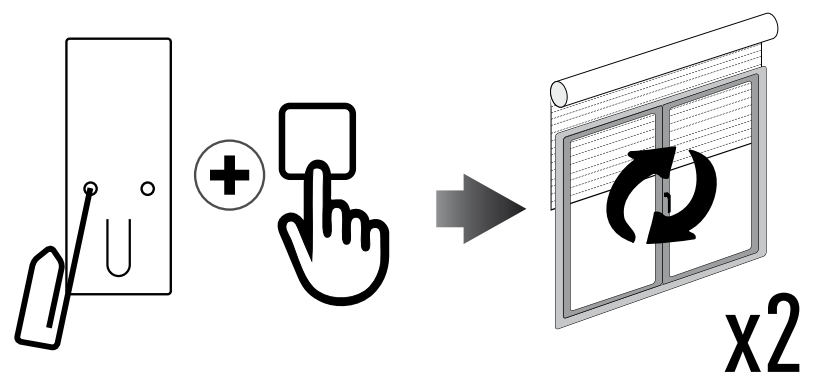

### OPTION 2 - Without an already programmed transmitter

1

Switch the motor power supply OFF. Then switch it ON

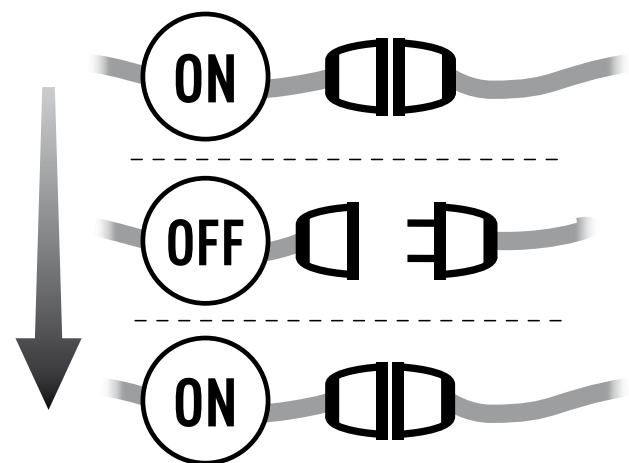

2

Within 8 seconds, using any Gapososa transmitter, press and hold both the PROG-TX and STOP buttons until the motor makes a long jog. Memory is now empty.

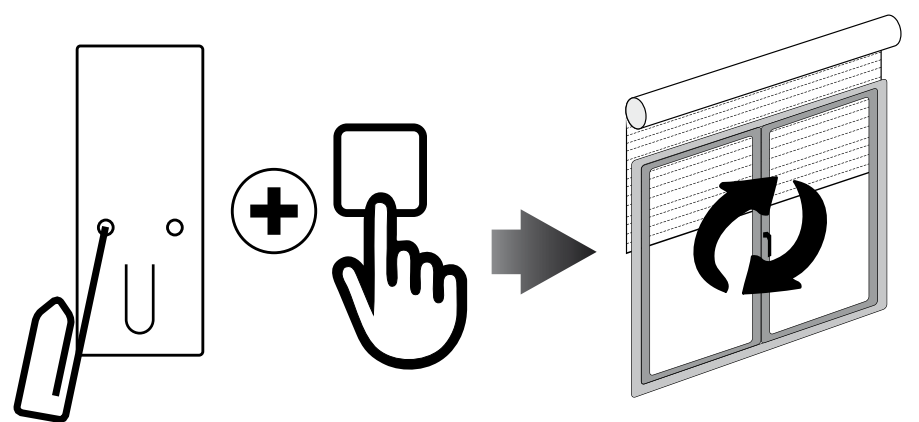



## RESET MOTOR MEMORY FOR LI-ION BATTERY MOTOR

### Option 1 - Using a programmed transmitter

Press and hold both the PROG-TX and STOP buttons until the motor makes first a brief jog and, after a while, a second, long jog. Memory is now empty.

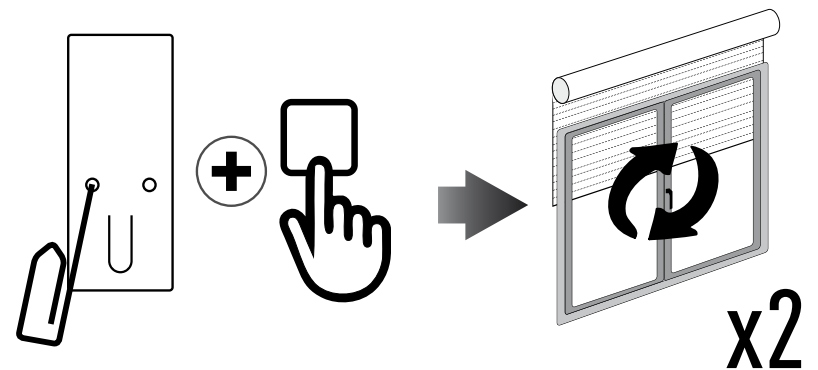

### Option 2 - Using a new transmitter without ID (not paired).

<b>1</b>	Activate sleep mode: click the push button (the motor makes 2 jogs)	
<b>2</b>	Wake up the motor: click the push button (the motor makes 1 jog)	
<b>3</b>	Within 8 seconds, using any Gaposa transmitter, press and hold both the PROG-TX and STOP buttons until the motor makes a long jog.	

# LIMIT SWITCH



## LIMIT SWITCH SETUP (Just for motors with electronic limit switch)

**ATTENTION: ALWAYS SET THE UP LIMIT FIRST**

<b>1</b>	Push the PROG-FC button until the motor makes a brief jog. <b>Note: during “programming mode” the operations are in “deadman control”</b>	
<b>2</b>	Press and hold the UP button and run the motor to the desired UP limit position.	
<b>3</b>	Press STOP to set the UP limit position. The motor makes a brief jog.	
<b>4</b>	Press and hold the DOWN button and run the motor to the desired DOWN limit position.	
<b>5</b>	Press STOP to set the DOWN limit position. The motor makes a brief jog.	

Note: accurate limit setting can be performed when UPWARD or DOWNWARD by pressing the PROG-FC button a second time. The motor then moves slowly in steps towards the desired limit. Always press STOP button to set the limit position.

# SETTING THE LIMITS INDIVIDUALLY



If the limits need to be changed after the initial limit setting procedure, it is possible to change the limit positions individually. One limit can be set without the other limit needing to be set. The motor can be in any position to initiate the procedure.

**During “limit setting mode” the operations are in “deadman control” (The UP and DOWN buttons must be held DOWN in order to move the motor.).**

## TO CHANGE THE UP LIMIT:

<b>1</b>	From any point between the existing limits, press and hold both the PROG-FC button and the UP button until the motor makes a brief jog.	
<b>2</b>	Press and hold the UP button until the desired new UP limit is reached.	
<b>3</b>	Press the STOP button to set the limit. The motor makes a brief jog to confirm. The new up limit is set.	

# SETTING THE LIMITS INDIVIDUALLY

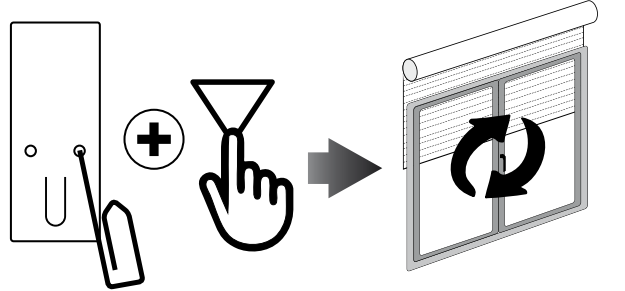
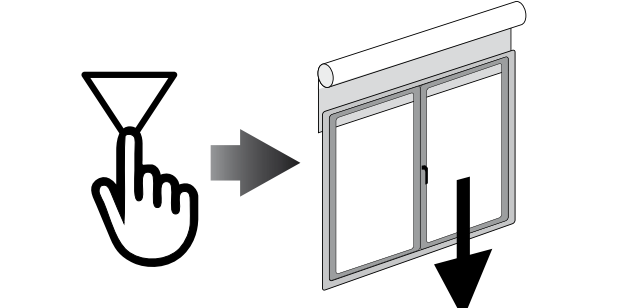
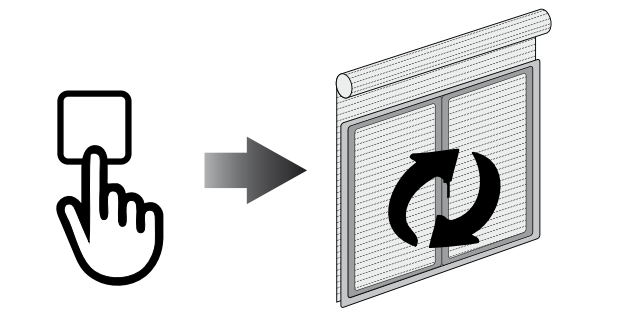

## TO CHANGE THE DOWN LIMIT:

<b>1</b>	From any point between the existing limits, press and hold both the PROG-FC button and the DOWN button until the motor makes a brief jog.	
<b>2</b>	Press and hold the DOWN button until the desired new DOWN limit is reached.	
<b>3</b>	Press the STOP button to set the limit. The motor makes a brief jog to confirm. The new up limit is set.	

# INTERMEDIATE POSITION



## INTERMEDIATE POSITION SETUP

1

Stop the shutter/awning in the desired intermediate position.

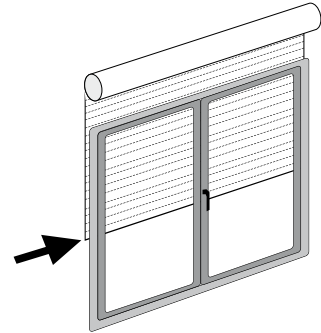

2

Press simultaneously the UP and DOWN buttons until the motor makes a brief movement in both directions. The intermediate position has been setup.

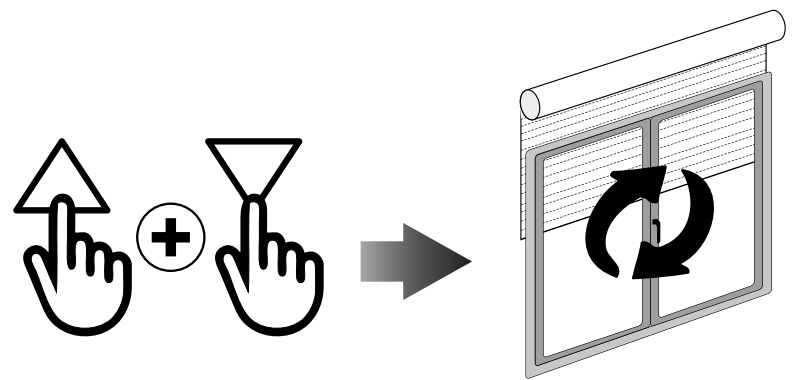

## RECALLING THE INTERMEDIATE POSITION

Keep the STOP button pressed at least for at least 3 seconds.

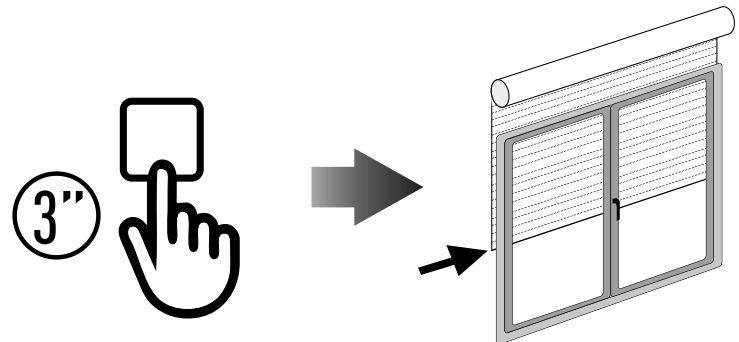

## ERASING THE INTERMEDIATE POSITION

Press simultaneously, both the UP and DOWN buttons until the motor makes a brief movement in both directions.

